

CA/CAT EN 733 ~ 3450 r.p.m.**CAX EN 733 ~ 3450 r.p.m.****4CA/4CAT EN 733 ~ 1750 r.p.m.****4CAX EN 733 ~ 1750 r.p.m.**CA/CAT
4CA/4CATCAX
4CAX
CARATTERISTICHE COSTRUTTIVE / CONSTRUCTION FEATURES
CARACTERÍSTICAS CONSTRUCTIVAS / CARACTÉRISTIQUES D'EXÉCUTION

Corpo pompa Pump body Cuerpo bomba Corps de pompe	ghisa (CA/CAT) - acciaio inossidabile AISI 316 (CAX) cast iron (CA/CAT) - stainless steel AISI 316 (CAX) fundición (CA/CAT) - acero inoxidable AISI 316 (CAX) fonte (CA/CAT) - acier inox AISI 316 (CAX)
Supporto motore Motor bracket Soporte motor Support moteur	ghisa cast iron fundición fonte
Girante Impeller Rodete Turbine	ghisa, bronzo, acciaio (CA/CAT) - acciaio (CAX) cast iron, bronze, steel (CA/CAT) - steel (CAX) fundición, bronce, acero (CA/CAT) - acero (CAX) fonte, bronze, acier (CA/CAT) - acier (CAX)
Tenuta Seal Sello Garniture	meccanica ceramica-grafite (CA/CAX) o a baderna cotone impregnato grafite (CAT) mechanical ceramic-graphite (CA/CAX) or gland packing graphite impregnated (CAT) mecánico cerámica-grafito (CA/CAX) o a trenza algodón impregnado de grafito (CAT) mécanique céramique-graphite (CA/CAX) ou à baderne coton imprégné graphite (CAT)
Sporgenza albero motore Pump shaft end Bomba eje Pompe arbre	acciaio AISI 316 stainless steel AISI 316 acero AISI 316 acier AISI 316
Temperatura del liquido Liquid temperature Temperatura del liquido Température du liquide	-10 ÷ +90 °C
Pressione di esercizio Operating pressure Presión de trabajo Pression de fonctionnement	max 10 bar max 14 bar (... -315 ~ 2900 r.p.m.)
MOTORE / MOTOR / MOTOR / MOTEUR	
Disponibile con motore classe di efficienza IE3 o standard Available with IE3 efficiency class motor or standard Disponibile con motor clase IE3 o estandar Disponible avec moteur classe IE3 ou standard	

Pompe centrifughe ad asse libero costruite secondo le norme EN 733; trovano vasto utilizzo nell'alimentazione idrica, negli impianti di pressurizzazione e antincendio; come standard vengono fornite di controflangia.

Bare shaft centrifugal pumps constructed to EN 733 standards; widely used in water supplies, pressurisation and fire-fighting systems, standard supply with counter-flange.

Bombas centrífugas de eje libre fabricadas según las normas EN 733; se utilizan en gran parte en la alimentación hídrica, en las instalaciones de presurización y antiincendio; según el estándar se suministran con contrabrida.

Pompes centrifuges à axe libre, fabriquées conformément aux normes EN 733. Elles trouvent une ample utilisation dans l'approvisionnement d'eau, dans les installations de pressurisation et anti-incendie; fournies de série avec contre-bride.

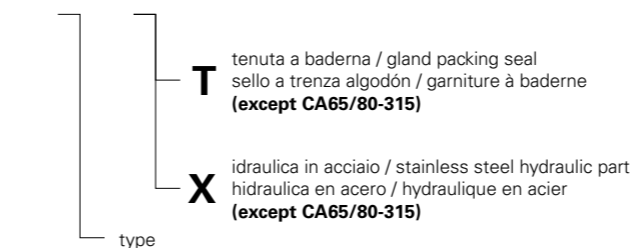
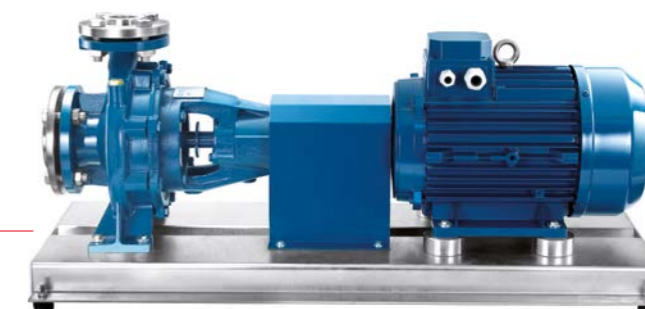
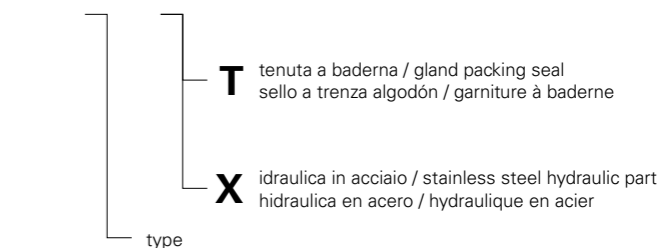
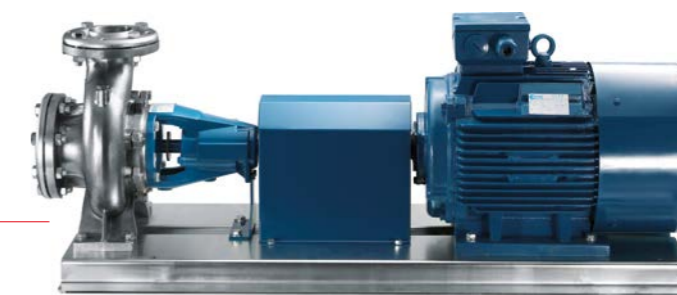
~ 3450 r.p.m. CA/CAT - CAX EN 733
~ 1750 r.p.m. 4CA/4CAT - 4CAX EN 733
VARIANTI COSTRUTTIVE / VERSIONS
VARIABLES COSTRUTTIVAS / VARIANTES DE CONSTRUCTIONS
CA**4CA**CA/CAT
4CA/4CATCAX
4CAXCA/CAX
4CA/4CAX
tenuta meccanica
mechanical seal
sello mecánico
garniture mécaniqueCAT
4CAT
tenuta a baderna
gland packing seal
sello a trenza algodón
garniture à baderne

TYPE	Nominal Power (kW)	Motor Size	Q (m³/h - l/min)													Q (m³/h - l/min)															
			0	4,5	6	7,5	9	12	15	18	21	24	27	30	33	36	39	42	48	54	60	66	72	78	84	96	108	120	132	144	
			0	75	100	125	150	200	250	300	350	400	450	500	550	600	650	700	800	900	1000	1100	1200	1300	1400	1600	1800	2000	2200	2400	
H (m)																H (m)															
pump input power (kW)																pump input power (kW)															
32-160C	1,5 2,2	90S 90L	24,5 0,73	24,3 0,98	24,0 1,07	23,6 1,16	23,1 1,24	21,7 1,39	19,7 1,52	17,3 1,62	14,5 1,71																				
32-160B	2,2	90L	28,5 0,97	28,5 1,25	28,3 1,36	27,9 1,46	27,5 1,56	26,4 1,75	24,7 1,92	22,4 2,06	19,6 2,17	16,6 2,28																			
32-160A	3	100L	35,7 1,24	35,9 1,61	35,8 1,74	35,4 1,88	35,0 2,01	33,8 2,27	32,6 2,50	30,7 2,70	27,9 2,88	24,8 3,03	21,8 3,16																		
32-200C	4	112M	41,0 1,52		39,7 2,20	39,6 2,37	39,3 2,53	38,3 2,84	36,9 3,13	35,2 3,38	33,0 3,61	30,4 3,82	27,6 4,02																		
32-200B	5,5	132S	50,1 2,34		50,2 3,31	50,1 3,53	49,9 3,75	49,3 4,14	48,0 4,50	46,4 4,84	44,5 5,15	42,4 5,43	39,8 5,69	37,2 5,92																	
32-200A	7,5	132S	58,6 3,03		59,0 3,96	58,9 4,19	58,8 4,43	58,2 4,90	57,1 5,36	55,5 5,76	53,4 6,11	51,1 6,52	48,4 6,92	45,6 7,22	42,5 7,45																
32-250C	11	160M	70,0 4,89			68,5 6,15	68,0 6,48	67,0 7,11	65,5 7,74	63,5 8,19	61,5 8,54	58,7 8,89	55,0 9,24	50,5 9,63																	
32-250B	11 15	160M 160M	82,0 6,45			81,0 8,02	80,5 8,35	79,5 9,00	78,5 9,56	77,0 10,1	75,0 10,5	72,6 11,2	70,0 11,8	66,5 12,1																	
32-250A	15	160M	93,0 7,85			92,5 9,30	92,0 9,88	91,5 10,7	90,5 11,4	89,5 12,2	88,0 12,9	85,7 13,6	83,5 14,3	80,0 14,9																	
40-125C	1,5	90S	19,0 0,69				19,3 1,05	19,1 1,18	18,6 1,30	17,9 1,40	17,0 1,48	16,1 1,55	14,8 1,60	13,3 1,63																	
40-125B	2,2	90L	23,0 0,86				23,3 1,28	23,2 1,45	22,9 1,60	22,4 1,74	21,6 1,86	20,8 1,96	19,7 2,04	18,3 2,10	16,6 2,15	14,8 2,19	13,0 2,22														
40-125A	3	100L	27,6 1,11				27,9 1,60	27,9 1,79	27,7 1,98	27,2 2,15	26,5 2,30	25,7 2,43	24,6 2,55	23,5 2,66	22,0 2,75	20,3 2,82	18,4 2,87	16,6 2,92													
40-160B	3 4	100L 112M	30,0 1,39				30,1 2,00	30,0 2,20	29,6 2,38	29,0 2,57	28,2 2,75	27,1 2,91	25,9 3,04	24,4 3,16	22,8 3,26	21,0 3,35	19,1 3,41														
40-160A	4 5,5	112M 132S	35,4 1,64				35,6 2,36	35,5 2,55	35,3 2,78	35,0 3,00	34,2 3,21	33,2 3,40	32,0 3,56	30,6 3,72	29,0 3,87	27,3 3,99	25,4 4,08	23,5 4,17													
40-200B	5,5	132S	44,7 2,30				44,9 3,30	44,8 3,60	44,6 3,80	44,0 4,20	42,9 4,60	41,6 4,60	40,0 5,00	38,1 5,30	36,1 5,40	33,6 5,60	30,8 5,70	27,9 6,00													
40-200A	7,5	132S	57,7 3,20				57,7 4,30	57,5 4,60	57,1 5,20	56,3 5,60	55,4 6,10	54,1 6,40	52,5 6,70	50,5 7,10	48,5 7,40	45,9 7,60	43,3 7,90	40,3 8,00													
40-250C	11	160M	63,0 4,40				62,6 5,60	62,4 6,08	61,9 6,61	61,3 7,13	60,5 7,63	59,7 8,10	58,6 8,57	57,1 9,04	55,0 9,45	52,4 9,83	49,6 10,22														
40-250B	11 15	160M 160M	70,8 5,16				71,3 6,65	71,2 7,22	71,0 7,76	70,5 8,28	69,8 8,80	68,4 9,33	66,6 9,86	65,4 10,35	63,8 10,82	61,2 11,25	58,5 11,69	55,6 12,11													
40-250A	15 18,5	160M 160L	86,1 6,70				86,3 8,24	86,5 8,89	86,4 9,58	86,0 10,29	85,6 10,97	85,0 11,65	84,1 12,31	82,9 12,95	81,3 13,55	79,4 14,13	77,0 14,74	74,3 15,32	67,9 16,27												
50-125B	3 4	100L 112M	19,9 1,22					20,2 1,77	20,2 1,94	20,1 2,11	20,0 2,22	19,8 2,33	19,3 2,44	19,1 2,55	18,7 2,65	18,3 2,76	17,8 2,87	17,4 2,98	16,4 3,10	15,3 3,20	14,0 3,30	12,7 3,39	11,2 3,43								
50-125A	4 5,5	112M 132S	24,5 1,78						25,0 2,54	24,9 2,70	24,8 2,85	24,6 3,01	24,4 3,17	24,2 3,33	23,8 3,42	23,5 3,50	23,1 3,59	22,7 3,67	21,8 4,14	20,8 4,42	19,6 4,58	18,1 4,74	16,5 4,90								
50-160B	5,5	132S	31,1 2,1									32,1 3,60	32,0 3,80	31,7 4,00	31,4 4,20	31,0 4,40	30,4 4,60	29,7 4,70	28,9 4,90	27,3 4,90	25,3 5,40	23,1 5,50	20,7 5,50	18,0 5,60	15,2 5,70						
50-160A	7,5	132S	36,7 2,6									37,9 4,20	37,8 4,50	37,7 4,90	37,4 5,10	37,1 5,40	36,6 5,60	36,1 5,90	35,4 6,20	33,9 6,50	32,1 6,90	30,0 7,10	27,8 7,30	25,3 7,50	22,6 7,60						
50-200C	11	160M	46,0 3,25										45,6 6,08	45,1 6,30	44,5 6,53	43,7 6,76	42,9 7,11	41,8 7,46	40,8 7,82	38,5 8,17	35,9 8,33	33,0 8,50	29,0 8,78	24,5 9,06							
50-200B	11	160M	50,8 3,38										51,0 6,68	50,5 7,53	50,0 7,80	49,3 8,20	48,5 8,46	47,7 8,81	46,8 9,15	44,7 9,50	42,2 9,85	39,5 10,10	35,9 10,40	32,0 10,64							
50-200A	15	160M	58,0 4,63										58,3 7,89	58,0 8,28	57,5 8,67	57,0 9,08	56,4 9,49	55,7 9,89	55,0 10,30	53,2 10,71	51,3 11,30	49,0 11,89	46,3 12,30	42,8 12,70	38,8 13,04						
50-250C	15 18,5	160M 160L	71,5 6,74										70,8 11,32	70,3 11,90	69,7 12,50	69,0 12,90	68,3 13,40	67,6 13,77	66,0 14,60	64,0 15,50	61,5 16,32	58,6 17,00	55,0 17,68	50,5 18,40							
50-250B	18,5 22	160L 180M	78,0 6,87										78,0 11,98	77,4 12,70	76,8 13,31	76,1 14,00	75,3 14,60	74,5 15,30	72,8 15,87	70,6 16,90	68,2 17,88	65,5 18,60	62,2 19,27	58,3 20,22							
50-250A	22 30	180M 200L	90,0 10,10										89,5 15,63	88,8 16,30	88,3 16,98	87,7 17,60	86,9 18,22	86,1 19,20	84,5 20,10	82,7 21,12	80,5 22,00	78,0 22,96	75,2 23,90	71,7 24,80							
50-315DN <small>No EN 733; only CA version</small>	37	200L	87,8 11,19														90,4 20,11	90,2 21,53	89,9 22,91	89,2 24,19	88,2 25,41	87,1 26,59	86,0 27,71	84,8 28,79	82,4 30,91	79,9 32,95	76,9 34,81	73,4 36,56			
50-315CN <small>No EN 733; only CA version</small>	45	225M	101,8 13,32														105,0 23,97	104,8 25,62	104,3 27,25	103,7 28,79	102,7 30,21	101,5 31,54	100,3 32,85	99,1 34,15	96,7 36,68	94,1 39,07	91,3 41,26	88,7 43,26			
50-315BN <small>No EN 733; only CA version</small>	55	250M	122,3 17,44														124,3 29,30	124,5 31,27	124,7 33,28	124,4 35,14	123,6 36,80	122,5 38,34	121,3 39,85	119,9 41,39	116,6 44,41	113,3 47,32	110,1 50,01	107,1 52,39	103,5 54,83		
50-315AN <small>No EN 733; only CA version</small>	75	280S	146,1 22,75														146,9 35,89	147,3 38,23	147,4 40,53	147,3 42,67	146,9 44,71	146,3 46,70	145,3 48,67	144,1 50,61	141,2 54,26	137,9 57,62	134,1 60,84	130,0 63,78	125,8 66,34		

32-160

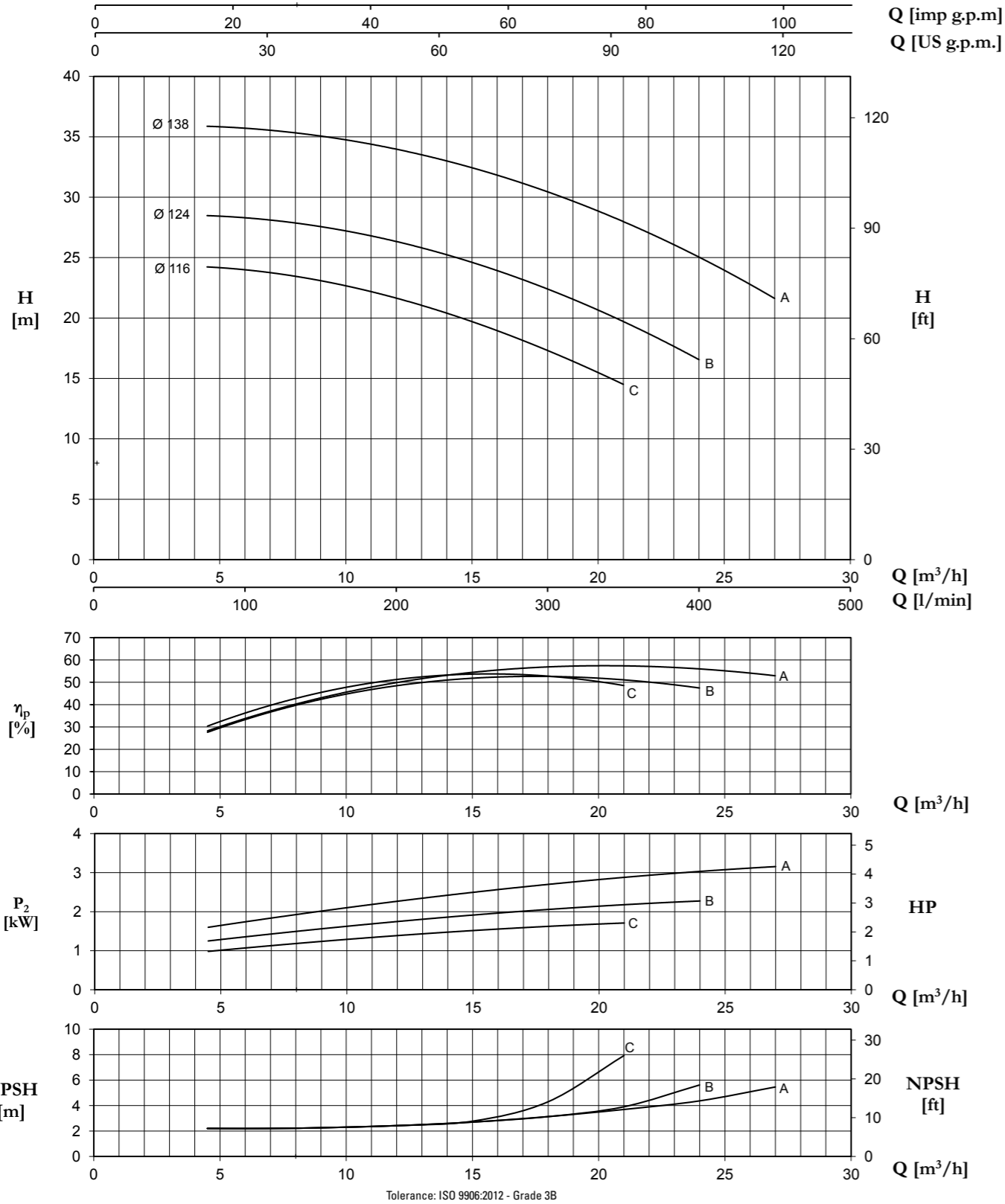

TYPE	Nominal Power (kW)	Motor Size	Q (m³/h - l/min)										
			0	4,5	6	9	12	15	18	21	24	27	
			0	75	100	150	200	250	300	350	400	450	
H (m) / pump input power (kW)													
32-160C	1,5	90S	24,5	24,3	24,0	23,1	21,7	19,7	17,3	14,5			
	2,2	90L	0,73	0,98	1,07	1,24	1,39	1,52	1,62	1,71			
32-160B	2,2	90L	28,5	28,5	28,3	27,5	26,4	24,7	22,4	19,6	16,6		
			0,97	1,25	1,36	1,56	1,75	1,92	2,06	2,17	2,28		
32-160A	3	100L	35,7	35,9	35,8	35,0	33,8	32,6	30,7	27,9	24,8	21,8	
			1,24	1,61	1,74	2,01	2,27	2,50	2,70	2,88	3,03	3,16	

32-200

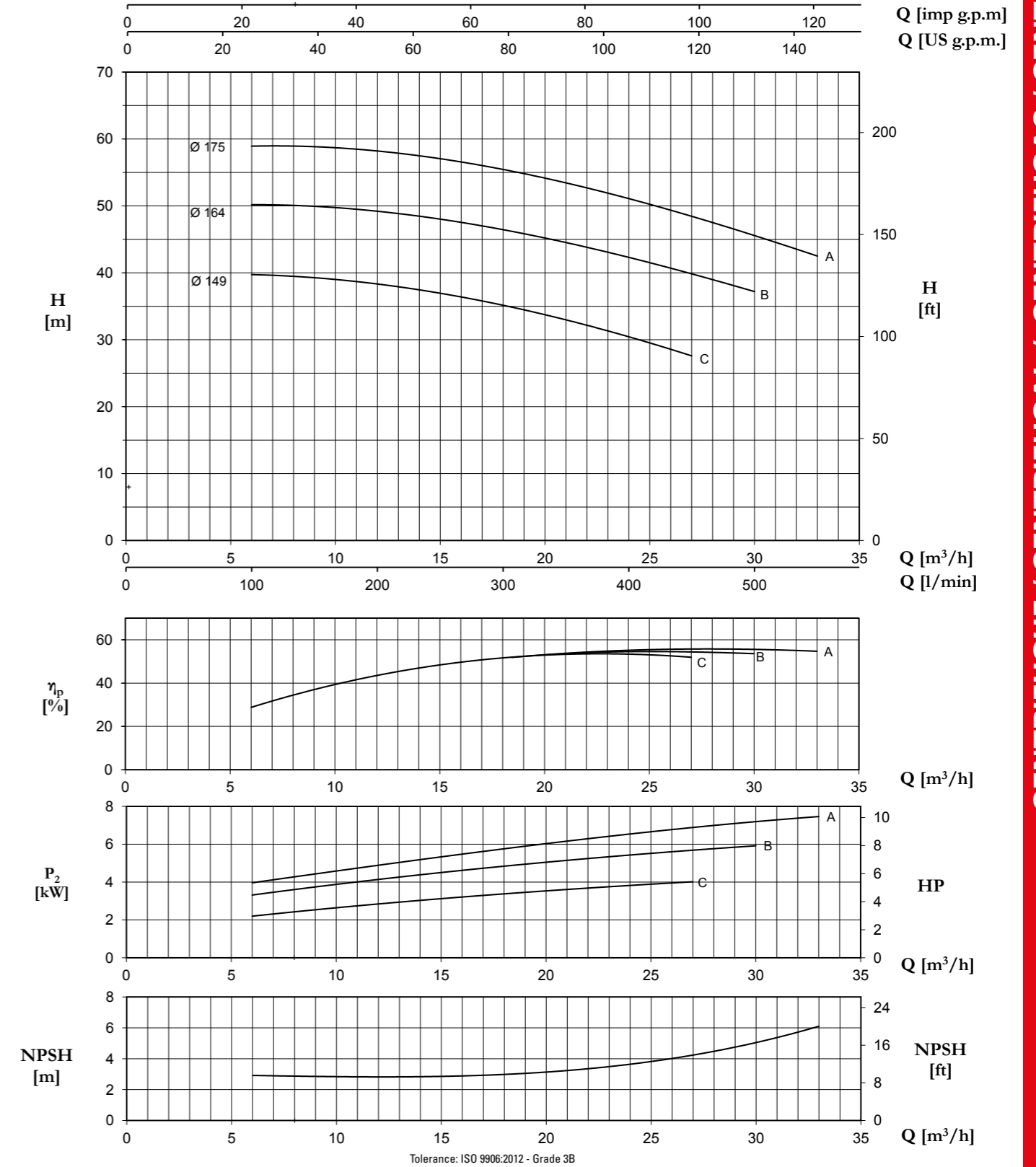

TYPE	Nominal Power (kW)	Motor Size	Q (m³/h - l/min)									
			0	6	9	12	15	21	24	27	30	33
			0	100	150	200	250	350	400	450	500	550
H (m) / pump input power (kW)												
32-200C	4	112M	40,1	39,7	39,3	38,3	36,9	33,0	30,4	27,6		
			1,52	2,20	2,53	2,84	3,13	3,61	3,82	4,02		
32-200B	5,5	132S	50,1	50,2	49,9	49,3	48,0	44,5	42,4	39,8	37,2	
			2,34	3,31	3,75	4,14	4,50	5,15	5,43	5,69	5,92	
32-200A	7,5	132S	58,6	59,0	58,8	58,2	57,1	53,4	51,1	48,4	45,6	42,5
			3,03	3,96	4,43	4,90	5,36	6,11	6,52	6,92	7,22	7,45

32-250

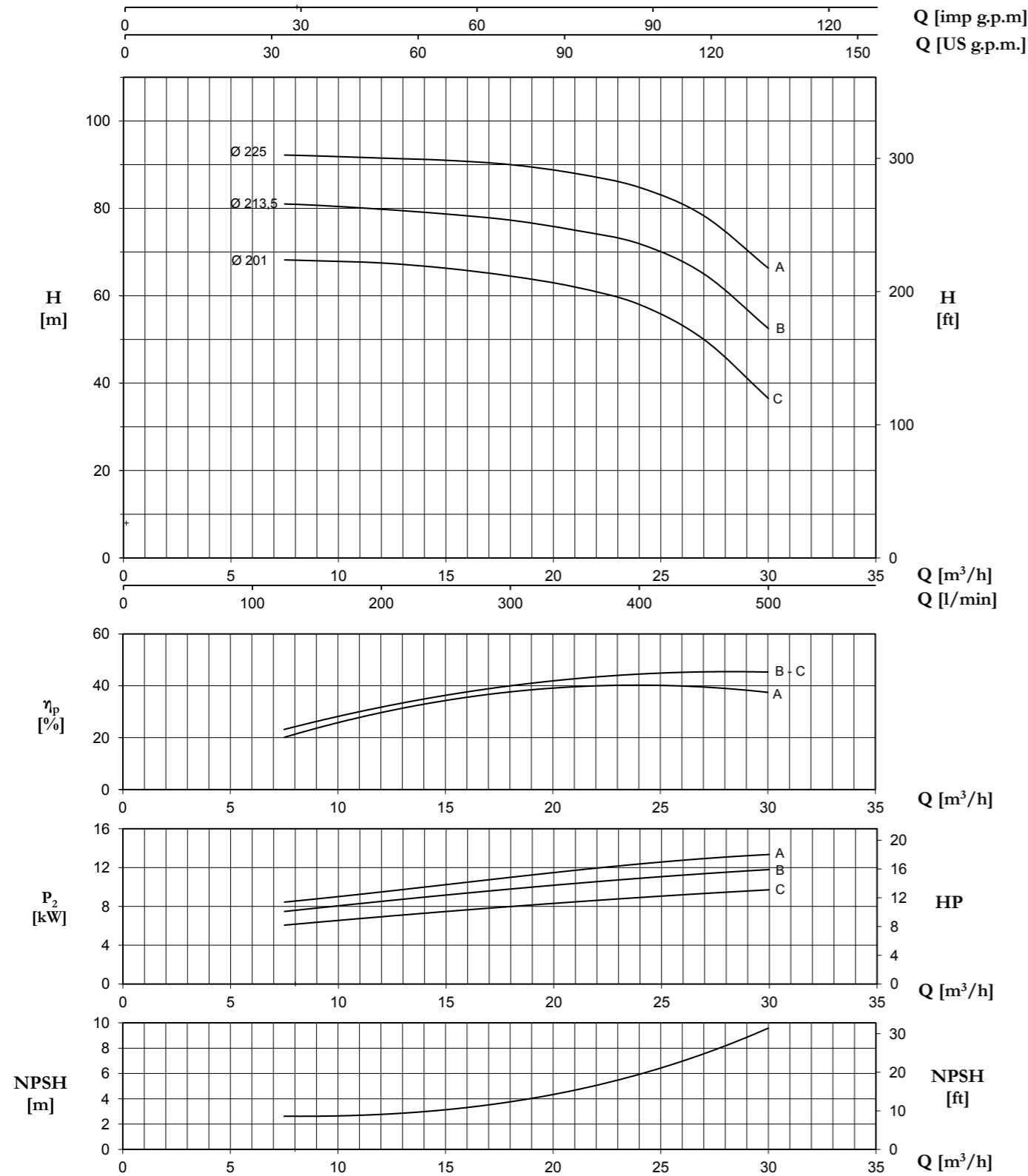

Tolerance: ISO 9906:2012 - Grade 3B

TYPE	Nominal Power (kW)	Motor Size	Q (m³/h - l/min)									
			0	7,5	9	12	15	18	21	24	27	30
			0	125	150	200	250	300	350	400	450	500
H (m) / pump input power (kW)												
32-250C	11	160M	70,0	68,5	68,0	67,0	65,5	63,5	61	58	50	36,5
	4,89		6,15	6,48	7,11	7,74	8,19	8,54	8,89	9,24	9,63	
32-250B	11	160M	82,0	81,0	80,5	79,5	78,5	77,0	74,5	71,9	65	52,5
	6,45	8,02	8,35	9,00	9,56	10,1	10,5	11,2	11,8	12,1		
32-250A	15	160M	93,0	92,5	92,0	91,5	90,5	89,5	87,5	85	78,5	66
			7,85	9,30	9,88	10,7	11,4	12,2	12,9	13,6	14,3	14,9

40-125

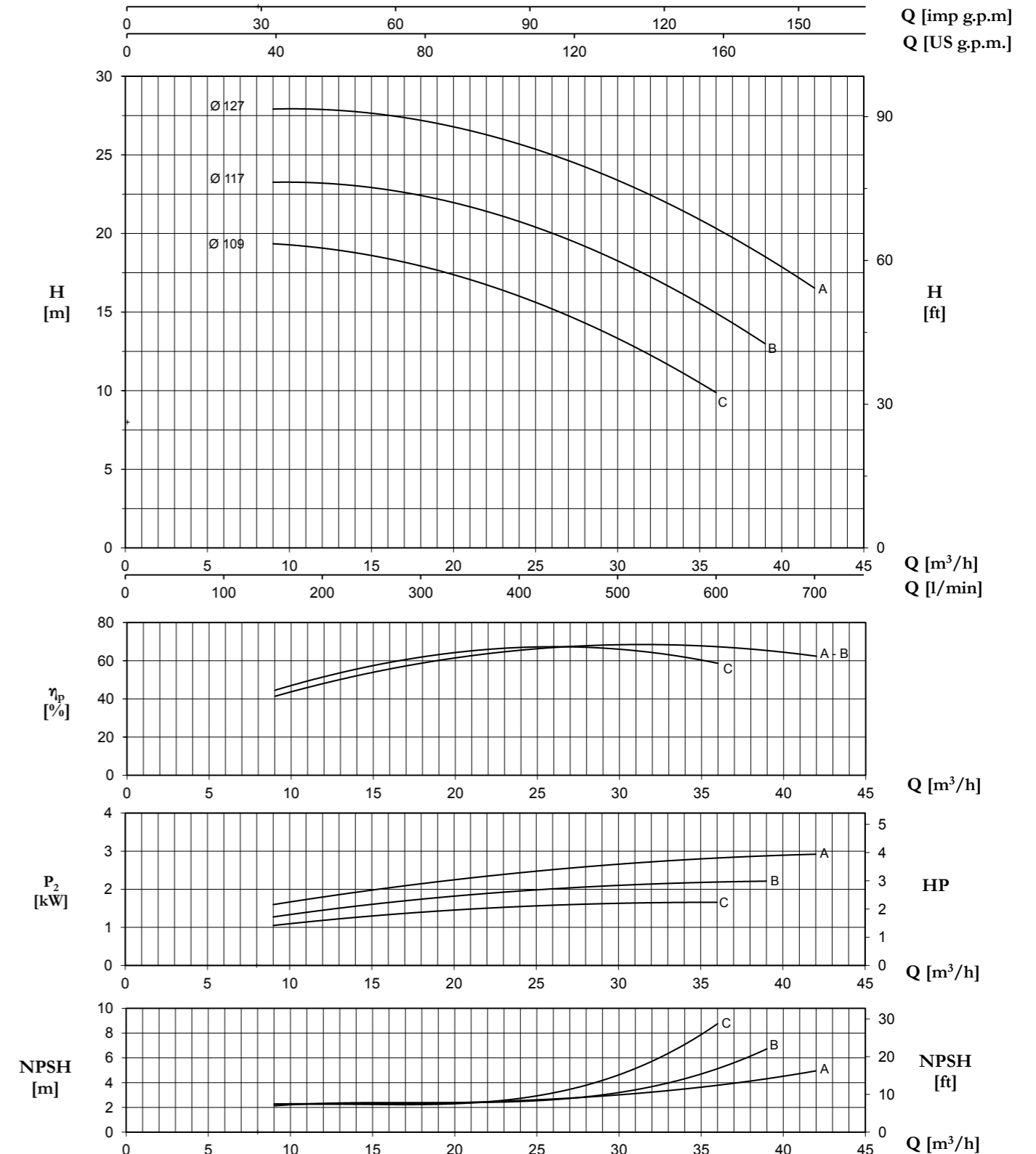

Tolerance: ISO 9906:2012 - Grade 3B

TYPE	Nominal Power (kW)	Motor Size	Q (m³/h - l/min)									
			0	9	15	21	27	33	36	39	42	
			0	150	250	350	450	500	550	600	650	700
H (m) / pump input power (kW)												
40-125C	1,5	90S	19,0	19,3	18,6	17,0	14,8	13,3	11,6	9,9	-	-
	0,69		1,05	1,30	1,48	1,60	1,63	1,65	1,66	1,66	-	-
40-125B	2,2	90L	23,0	23,3	22,9	21,6	19,7	18,3	16,6	14,8	13,0	-
	0,86		1,28	1,60	1,86	2,04	2,10	2,15	2,19	2,22	-	-
40-125A	3	100L	27,6	27,9	27,7	26,5	24,6	23,5	22,0	20,3	18,4	16,6
	1,11		1,60	1,98	2,30	2,55	2,66	2,75	2,82	2,87	2,92	

40-160

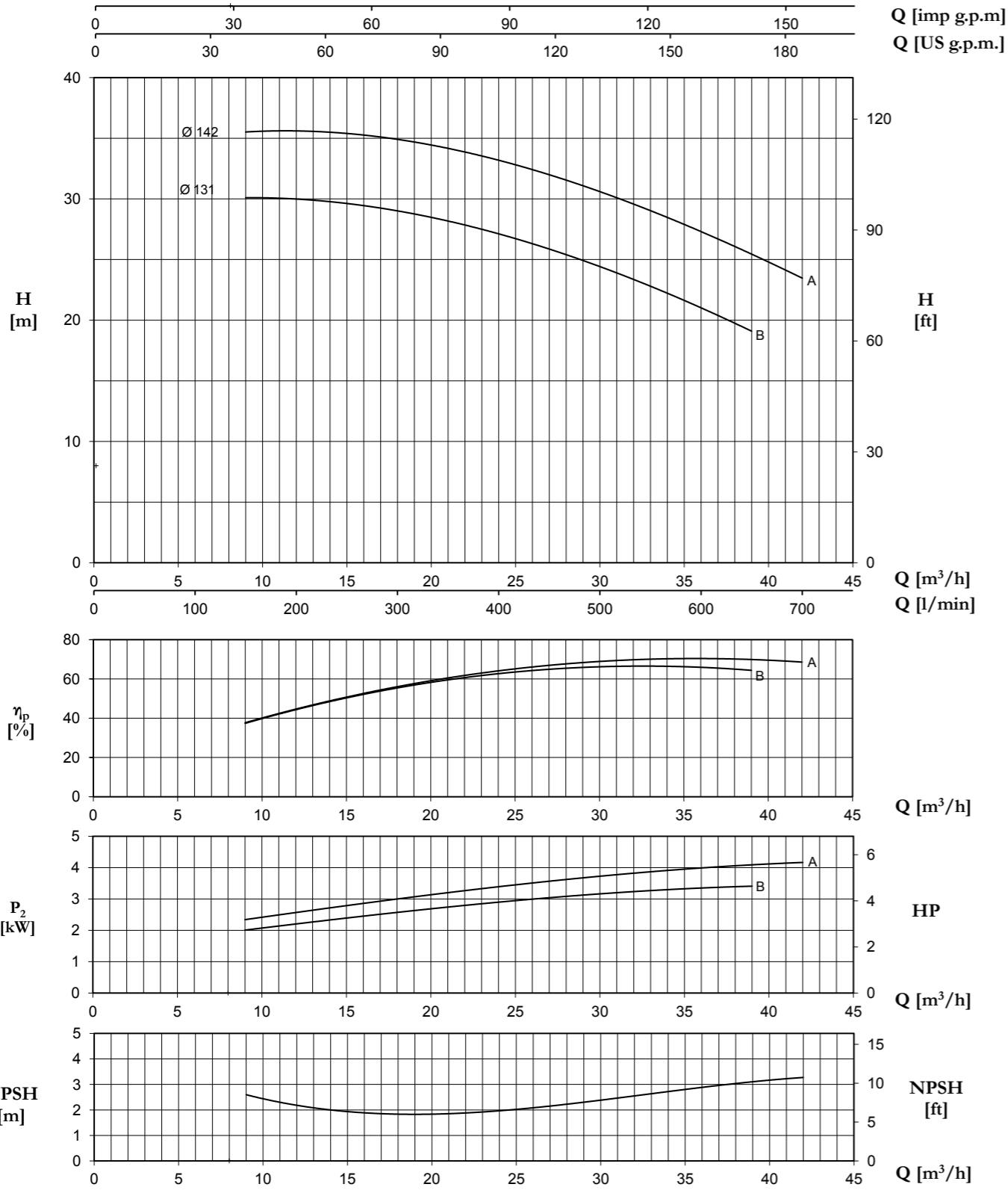

Tolerance: ISO 9906:2012 - Grade 3B

TYPE	Nominal Power (kW)	Motor Size	Q (m³/h - l/min)												
			0	9	12	15	18	21	24	27	30	33	36	39	42
			0	150	200	250	300	350	400	450	500	550	600	650	700
H (m) / pump input power (kW)															
40-160B	3	100L	30,0	30,1	30,0	29,6	29,0	28,2	27,1	25,9	24,4	22,8	21,0	19,1	
	4	112M	1,39	2,00	2,20	2,38	2,57	2,75	2,91	3,04	3,16	3,26	3,35	3,41	
40-160A	4	112M	35,4	35,6	35,5	35,3	35,0	34,2	33,2	32,0	30,6	29,0	27,3	25,4	23,5
	5,5	132S	1,64	2,36	2,55	2,78	3,00	3,21	3,40	3,56	3,72	3,86	3,99	4,08	4,17

40-200

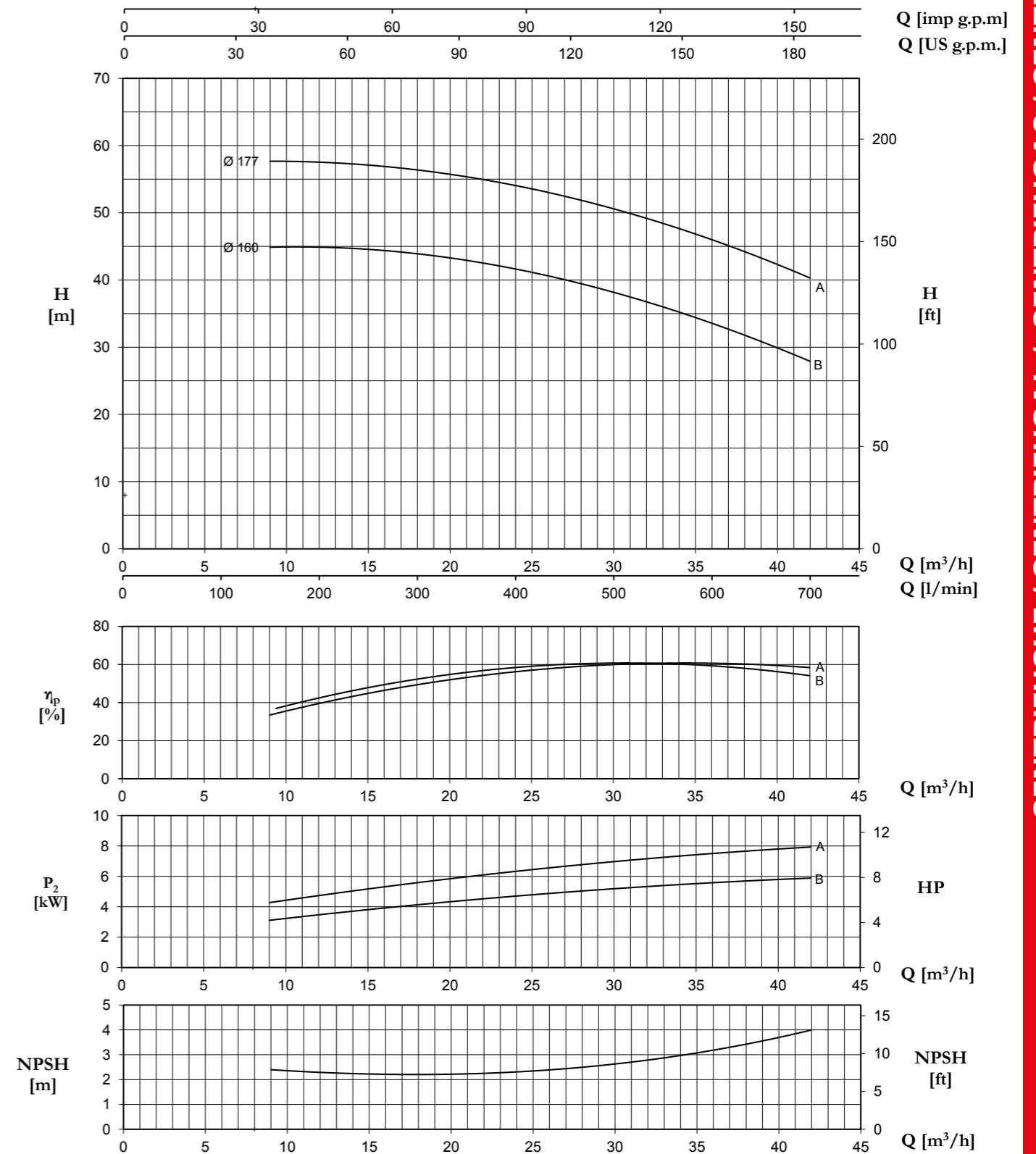

Tolerance: ISO 9906:2012 - Grade 3B

TYPE	Nominal Power (kW)	Motor Size	Q (m³/h - l/min)												
			0	9	12	15	18	21	24	27	30	33	36	39	42
			0	150	200	250	300	350	400	450	500	550	600	650	700
H (m) / pump input power (kW)															
40-200B	5,5	132S	44,7	44,9	44,8	44,6	44,0	42,9	41,6	40,0	38,1	36,1	33,6	30,8	27,9
			2,3	3,3	3,6	3,8	4,2	4,6	4,6	5,0	5,3	5,4	5,6	5,6	5,7
40-200A	7,5	132S	57,7	57,7	57,5	57,1	56,3	55,4	54,1	52,5	50,5	48,5	45,9	43,3	40,3
			3,2	4,3	4,6	5,2	5,6	6,1	6,4	6,7	7,1	7,4	7,6	7,9	8,0

40-250

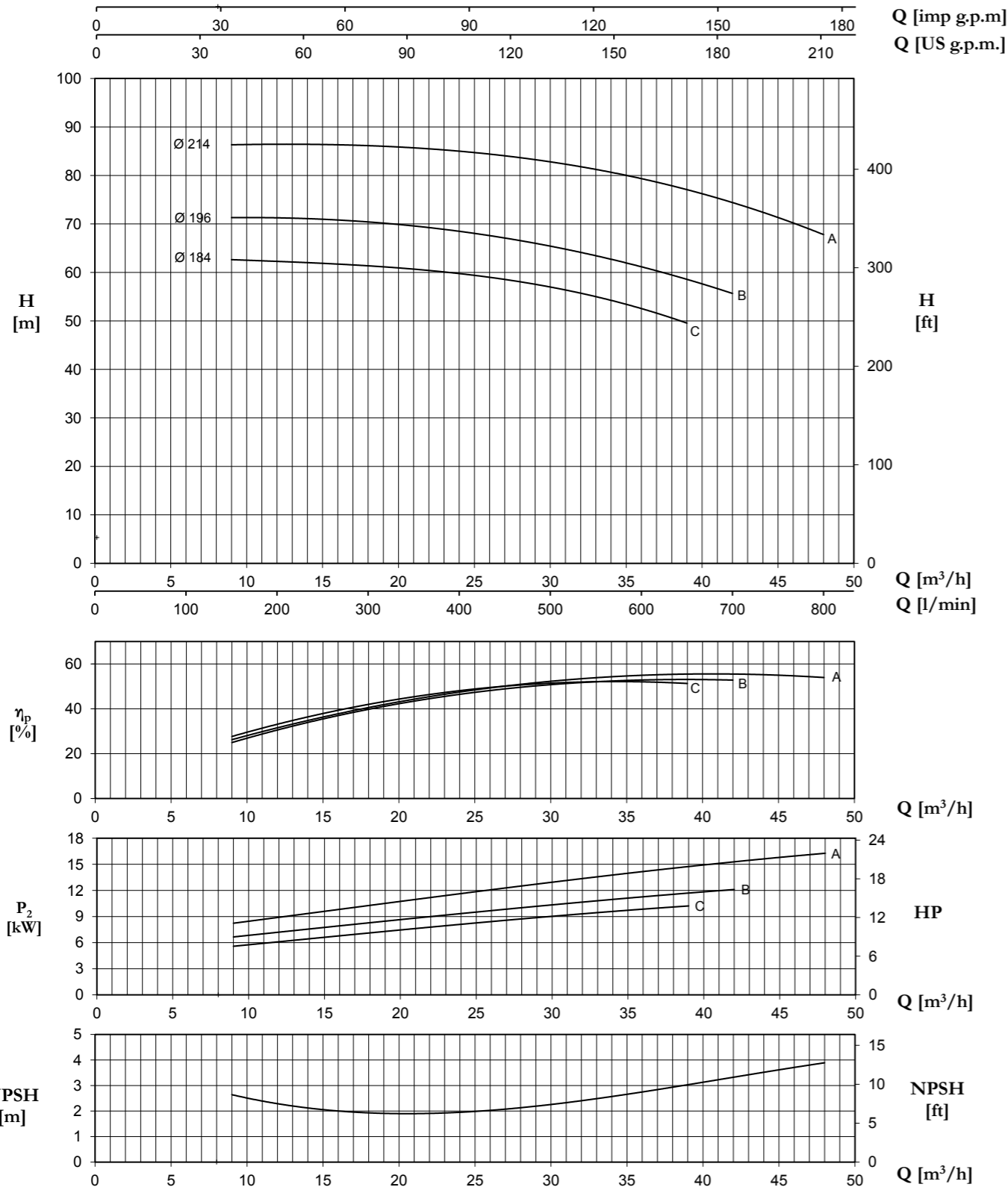

Tolerance: ISO 9906:2012 - Grade 3B

TYPE	Nominal Power (kW)	Motor Size	Q (m³/h - l/min)													
			H (m) / pump input power (kW)													
			0	9	12	15	18	21	24	27	30	33	36	39	42	48
40-250C	11	160M	63,0	62,6	62,4	61,9	61,3	60,5	59,7	58,6	57,1	55,0	52,4	49,6		
	4,40		5,60	6,08	6,61	7,13	7,63	8,10	8,57	9,04	9,45	9,83	10,22			
40-250B	11	160M	70,8	71,3	71,2	71,0	70,5	69,8	68,4	66,6	65,4	63,8	61,2	58,5	55,6	
	15	160M	5,16	6,65	7,22	7,76	8,28	8,80	9,33	9,86	10,35	10,82	11,25	11,69	12,11	
40-250A	15	160M	86,1	86,3	86,5	86,4	86,0	85,6	85,0	84,1	82,9	81,3	79,4	77,0	74,3	
	18,5	160L	6,70	8,24	8,89	9,58	10,29	10,97	11,65	12,31	12,95	13,55	14,13	14,74	15,32	

50-125

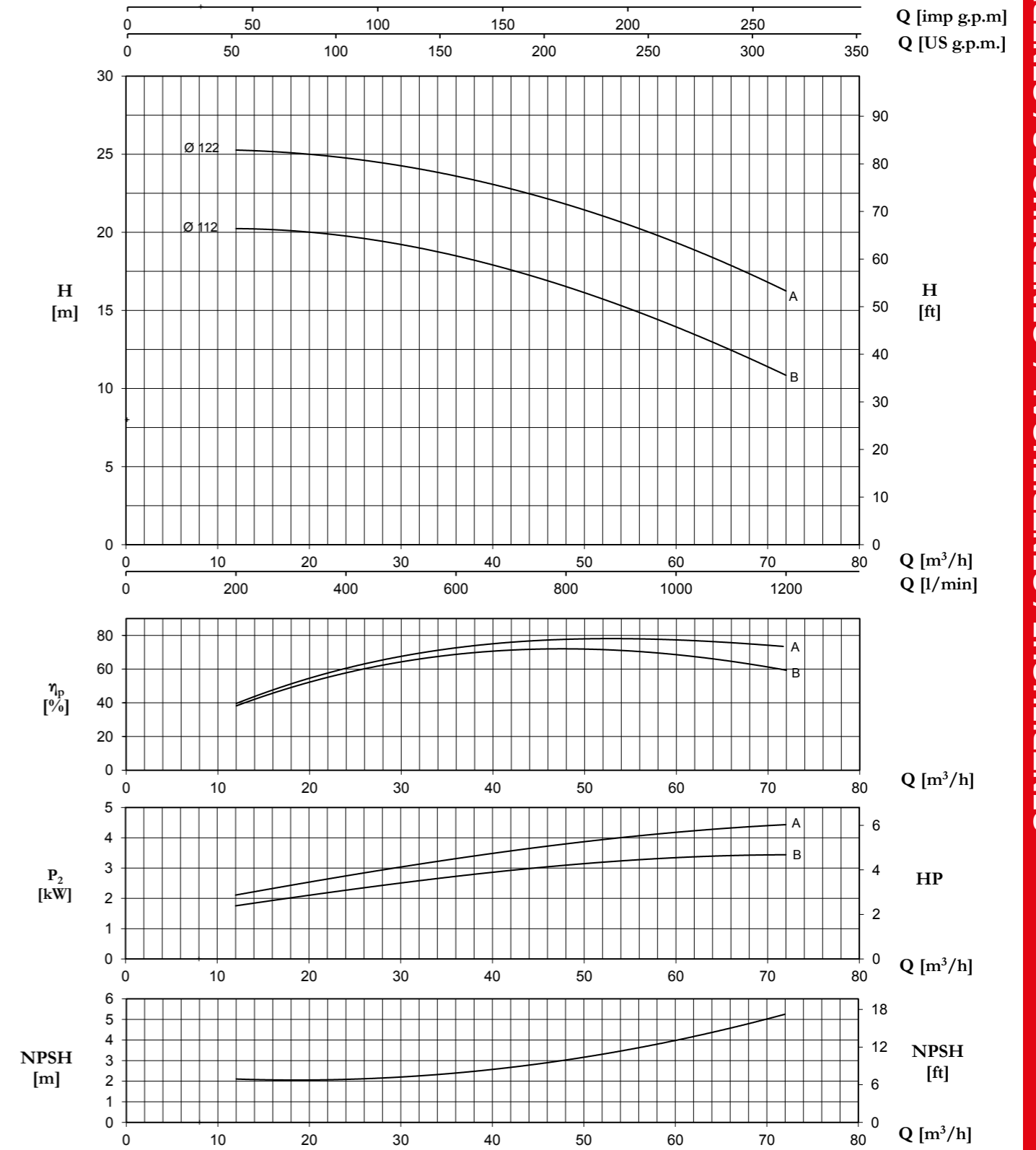

Tolerance: ISO 9906:2012 - Grade 3B

TYPE	Nominal Power (kW)	Motor Size	Q (m³/h - l/min)													
			H (m) / pump input power (kW)													
			0	12	15	18	21	24	27	30	33	36	39	42	48	54
50-125B	3	100L	19,9	20,2	20,2	20,1	20,0	19,8	19,3	19,1	18,7	18,3	17,8	17,4	16,4	
	4	112M	1,22	1,77	1,94	2,11	2,22	2,33	2,44	2,55	2,65	2,76	2,87	2,98	3,10	
50-125A	4	112M	24,5	24,9	24,8	24,6	24,4	24,2	23,8	23,5	23,1	22,7	21,8	20,8		
	5,5	132S	1,78	2,54	2,70	2,85	3,01	3,17	3,33	3,42	3,50	3,59	3,67	4,14		

50-160

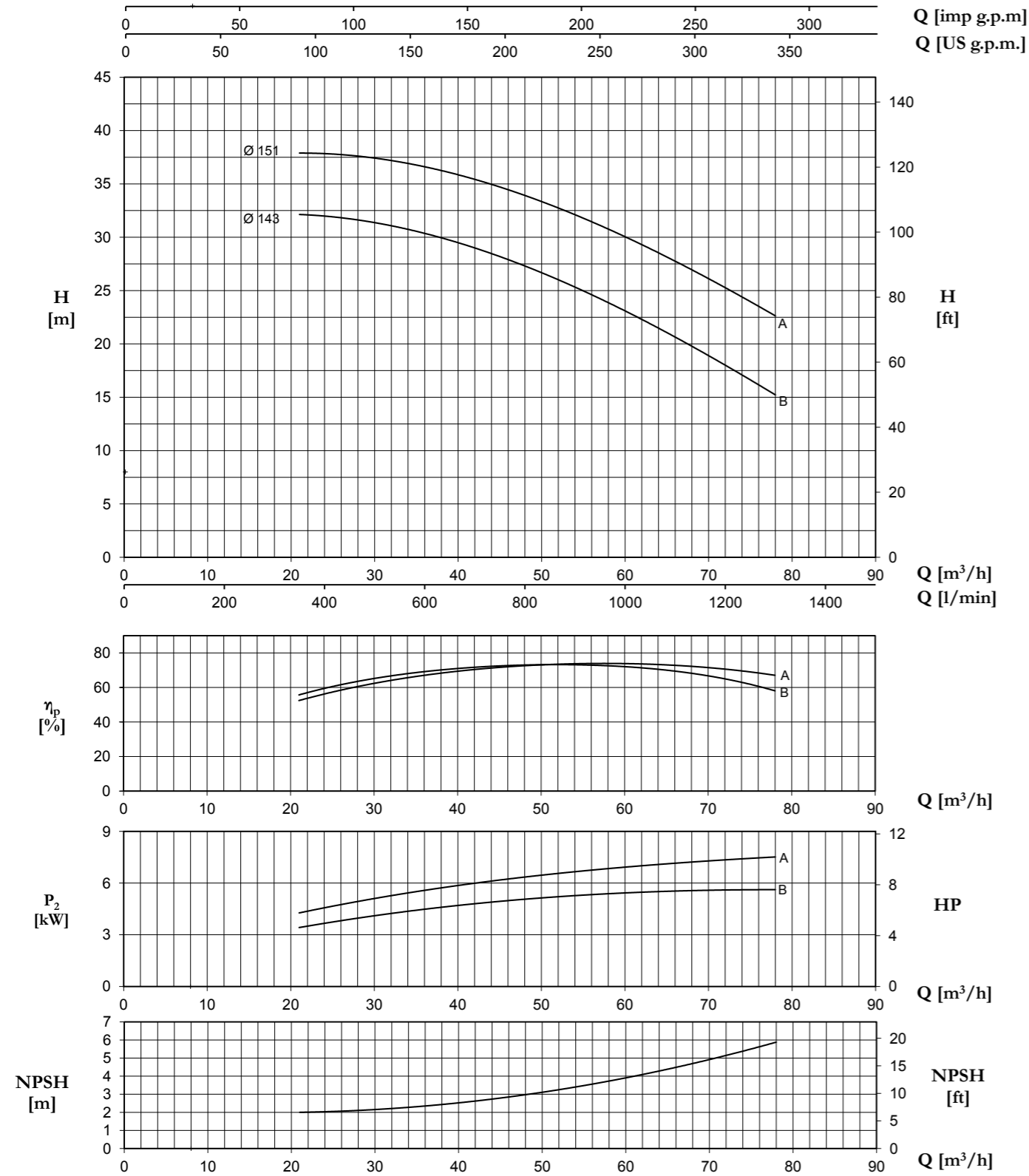

Tolerance: ISO 9906:2012 - Grade 3B

TYPE	Nominal Power (kW)	Motor Size	Q (m³/h - l/min)														
			H (m) / pump input power (kW)														
			0	21	24	27	30	33	36	39	42	48	54	60	66	72	78
50-160B	5,5	132S	31,1	32,1	32,0	31,7	31,4	31,0	30,4	29,7	28,9	27,3	25,3	23,1	20,7	18,0	15,2
50-160A	7,5	132S	36,7	37,9	37,8	37,7	37,4	37,1	36,6	36,1	35,4	33,9	32,1	30,0	27,8	25,3	22,6

50-200

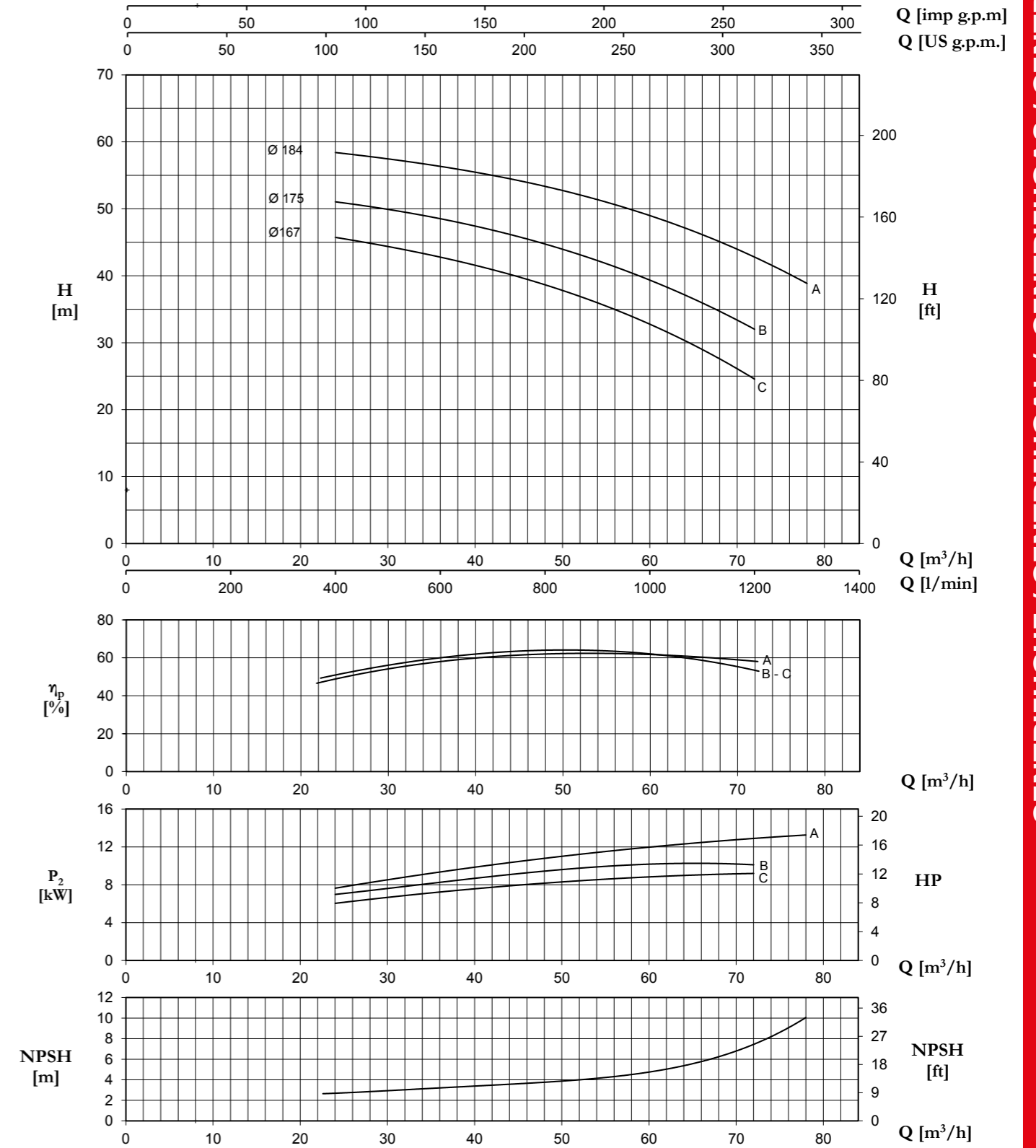

Tolerance: ISO 9906:2012 - Grade 3B

TYPE	Nominal Power (kW)	Motor Size	Q (m³/h - l/min)														
			H (m) / pump input power (kW)														
			0	24	27	30	33	36	39	42	48	54	60	66	72	78	
50-200C	11	160M	46,0	45,6	45,1	44,5	43,7	42,9	41,8	40,8	38,5	35,9	33,0	29,0	24,5		
50-200B	11	160M	50,8	51,0	50,5	50,0	49,3	48,5	47,7	46,8	44,7	42,2	39,5	35,9	32,0		
50-200A	15	160M	58,0	58,3	58,0	57,5	57,0	56,4	55,7	55,0	53,2	51,3	49,0	46,3	42,8	38,8	

CA/CAT - CAX EN 733 ~ 3450 r.p.m.

50-250

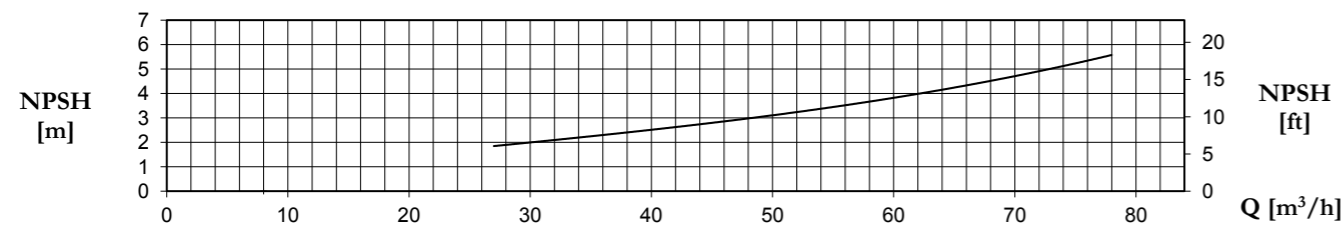
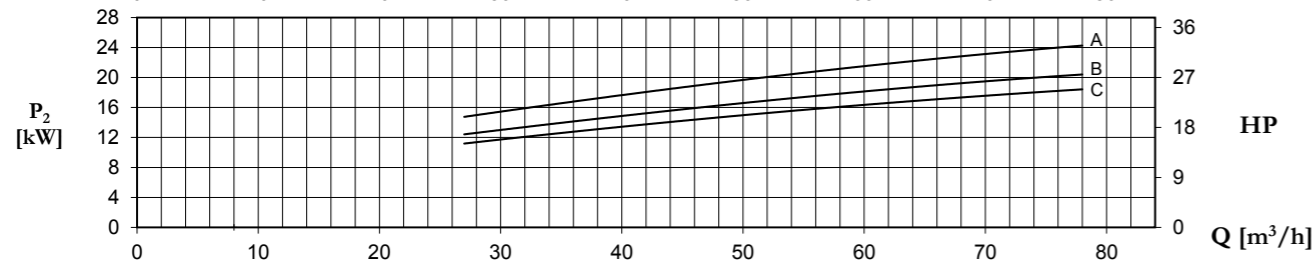
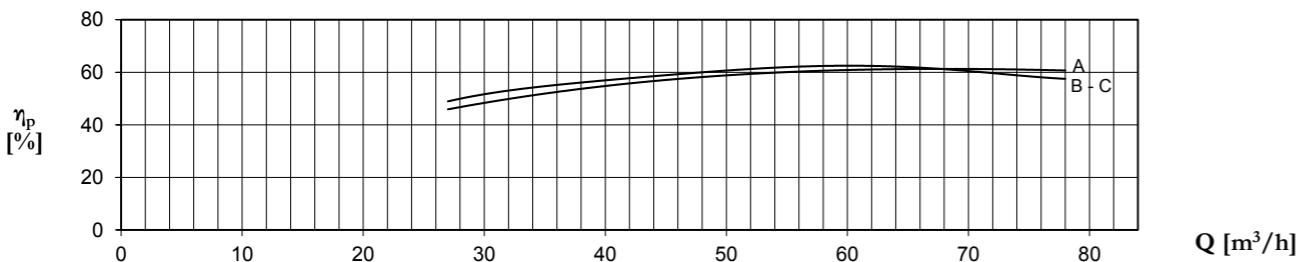
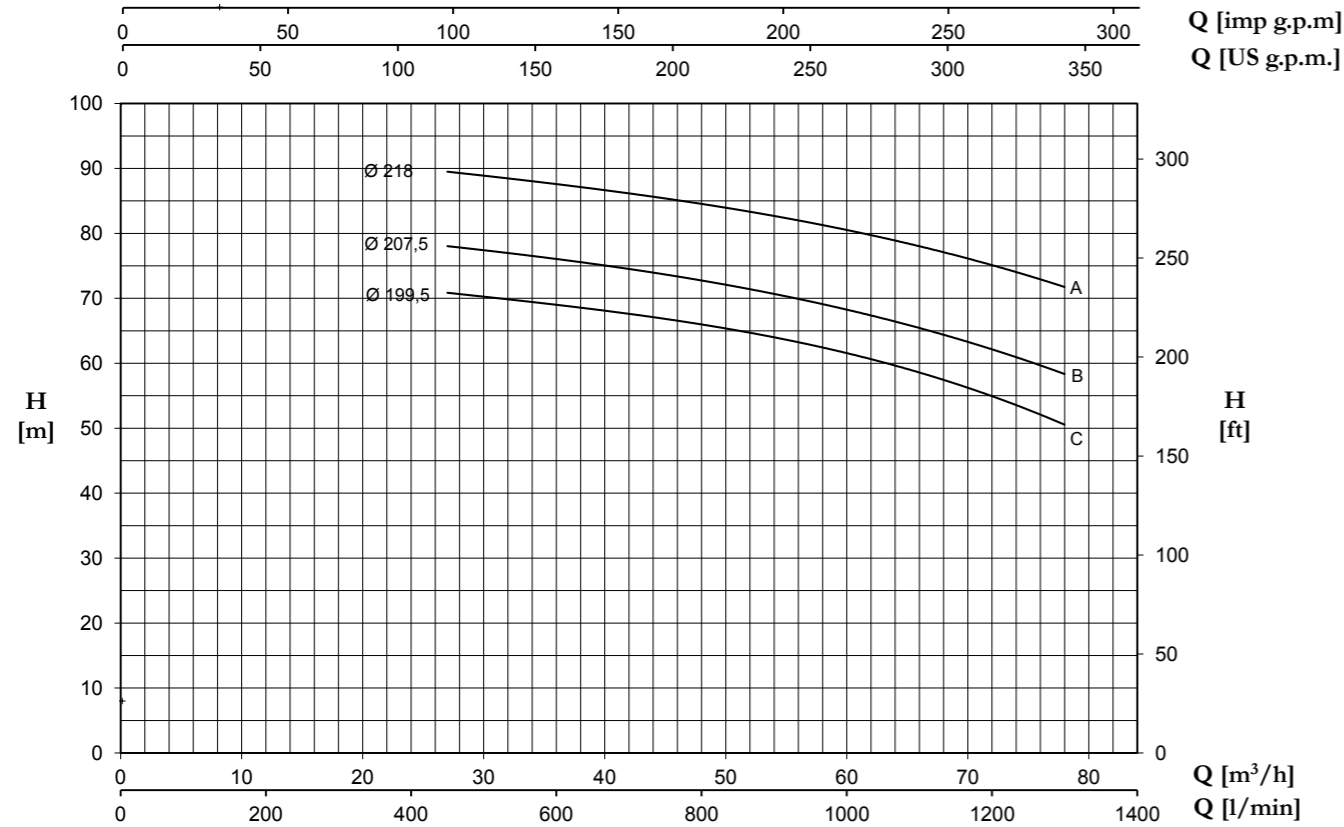

Tolerance: ISO 9906:2012 - Grade 3B

TYPE	Nominal Power (kW)	Motor Size	Q (m³/h - l/min)												
			0	27	30	33	36	39	42	48	54	60	66	72	78
			0	450	500	550	600	650	700	800	900	1000	1100	1200	1300
H (m) / pump input power (kW)															
50-250C	15	160M	71,5	70,8	70,3	69,7	69,0	68,3	67,6	66,0	64,0	61,5	58,6	55,0	50,5
	18,5	160L	6,74	11,3	11,9	12,5	12,9	13,4	13,8	14,6	15,5	16,3	17,0	17,7	18,4
50-250B	18,5	160L	78,0	78,0	77,4	76,8	76,1	75,3	74,5	72,8	70,6	68,2	65,5	62,2	58,3
	22	180M	6,87	12,0	12,7	13,3	14,0	14,6	15,3	15,9	16,9	17,9	18,6	19,3	20,2
50-250A	22	180M	90,0	89,5	88,8	88,3	87,7	86,9	86,1	84,5	82,7	80,5	78,0	75,2	71,7
	30	200L	10,1	15,6	16,3	17,0	17,6	18,2	19,2	20,1	21,1	22,0	23,0	23,9	24,8

~ 3450 r.p.m. CA (No EN 733; only CA version)

50-315

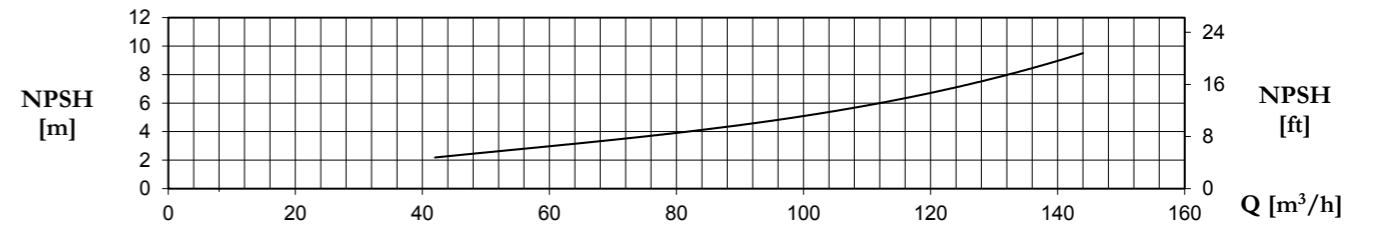
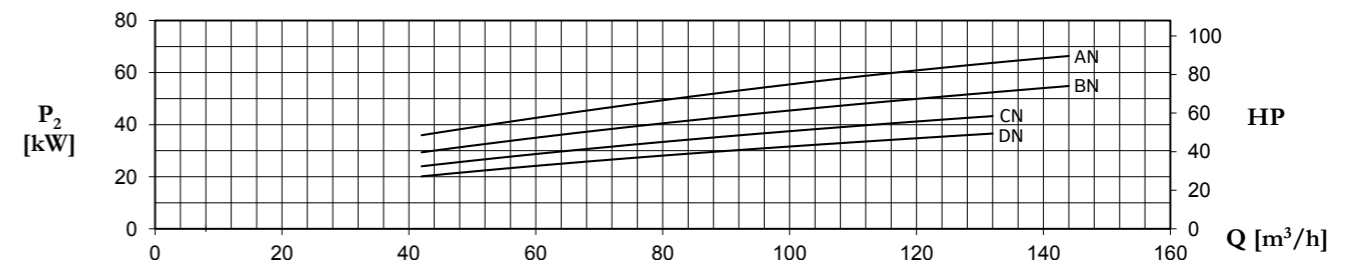
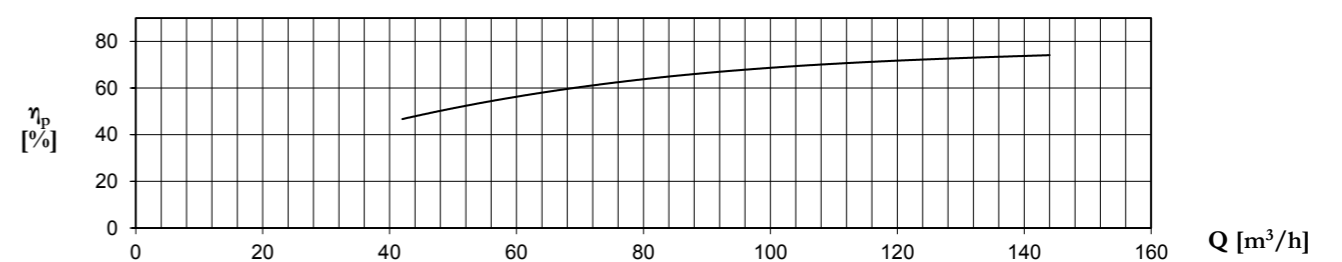
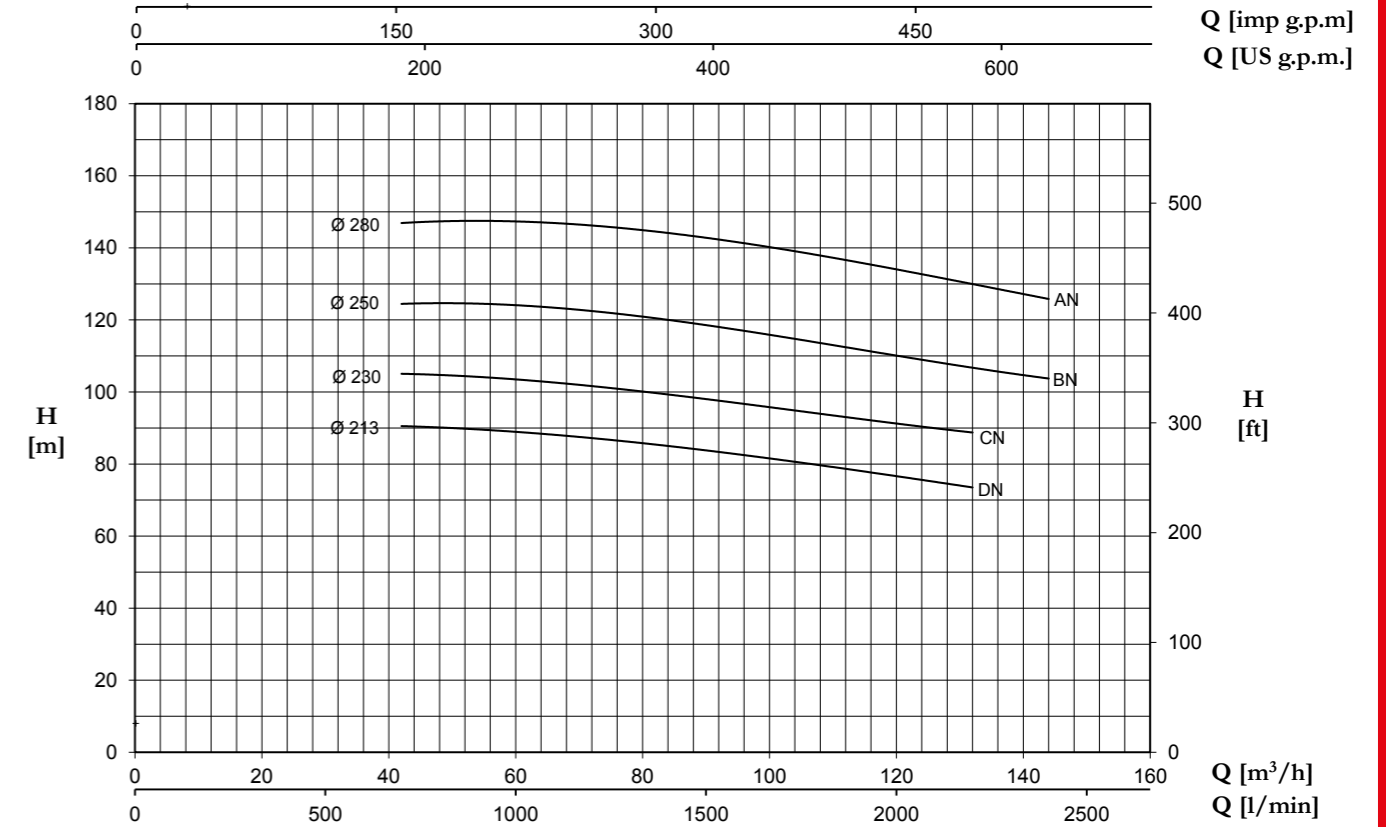

Tolerance: ISO 9906:2012 - Grade 3B

TYPE	Nominal Power (kW)	Motor Size	Q (m³/h - l/min)									
			0	42	54	66	78	96	120	132	144	
			0	700	900	1100	1300	1600	2000	2200	2400	
H (m) / pump input power (kW)												
50-315DN	37	200L	87,8	90,4	89,9	88,2	86,0	82,4	76,9	73,4		
			11,19	20,11	22,91	25,41	27,71	30,91	34,81	36,56		
50-315CN	45	225M	101,8	105,0	104,3	102,7	100,3	96,7	91,3	88,7		
			13,32	23,97	27,25	30,21	32,85	36,68	41,26	43,26		
50-315BN	55	250M	122,3	124,3	124,7	123,6	121,3	116,6	110,1	107,1	103,5	
			17,44	29,30	33,28	36,80	39,85	44,41	50,01	52,39	54,83	
50-315AN	75	280S	146,1	146,9	147,4	146,9	145,3	141,2	134,1	130,0	125,8	
			22,75	35,89	40,53	44,71	48,67	54,26	60,84	63,78	66,34	

65-125

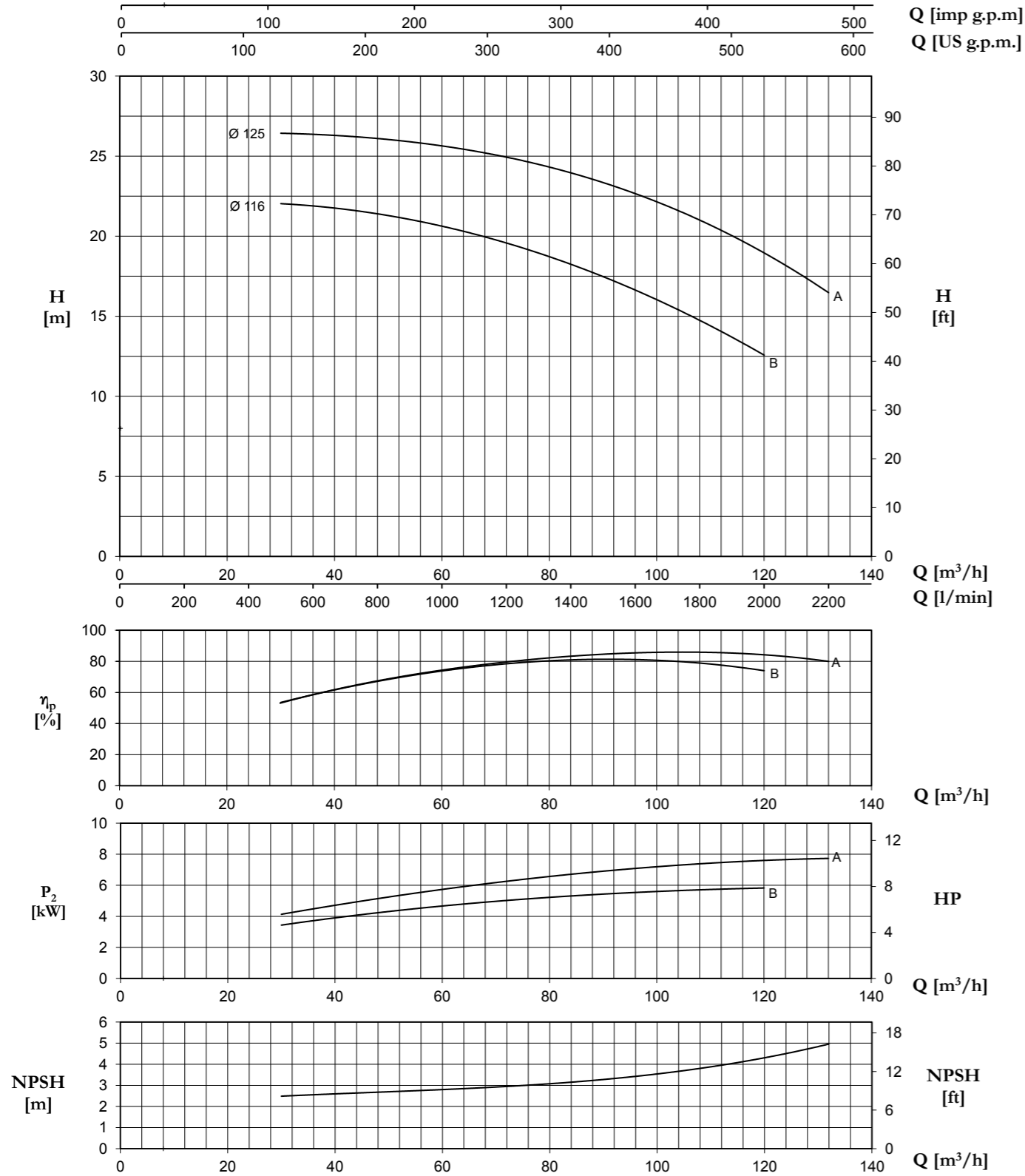

Tolerance: ISO 9906:2012 - Grade 3B

TYPE	Nominal Power (kW)	Motor Size	Q (m³/h - l/min)																
			H (m) / pump input power (kW)																
			0	30	33	36	39	42	48	54	60	66	72	78	84	96	108	120	132
65-125B	5,5	132S	20,9 2,3	22,0 3,6	22,0 3,7	21,9 3,8	21,8 3,9	21,7 4,0	21,4 4,3	21,0 4,6	20,6 4,7	20,1 5,0	19,6 5,1	19,0 5,2	18,3 5,4	16,6 5,4	14,7 5,8	12,6 5,9	
65-125A	7,5	132S	25,4 2,8	26,4 4,1	26,4 4,3	26,4 4,6	26,3 4,7	26,3 4,9	26,1 5,2	25,9 5,5	25,6 5,9	25,3 6,1	24,9 6,4	24,5 6,7	24,0 6,9	22,7 7,2	21,0 7,5	18,9 7,7	16,5 7,8

65-160

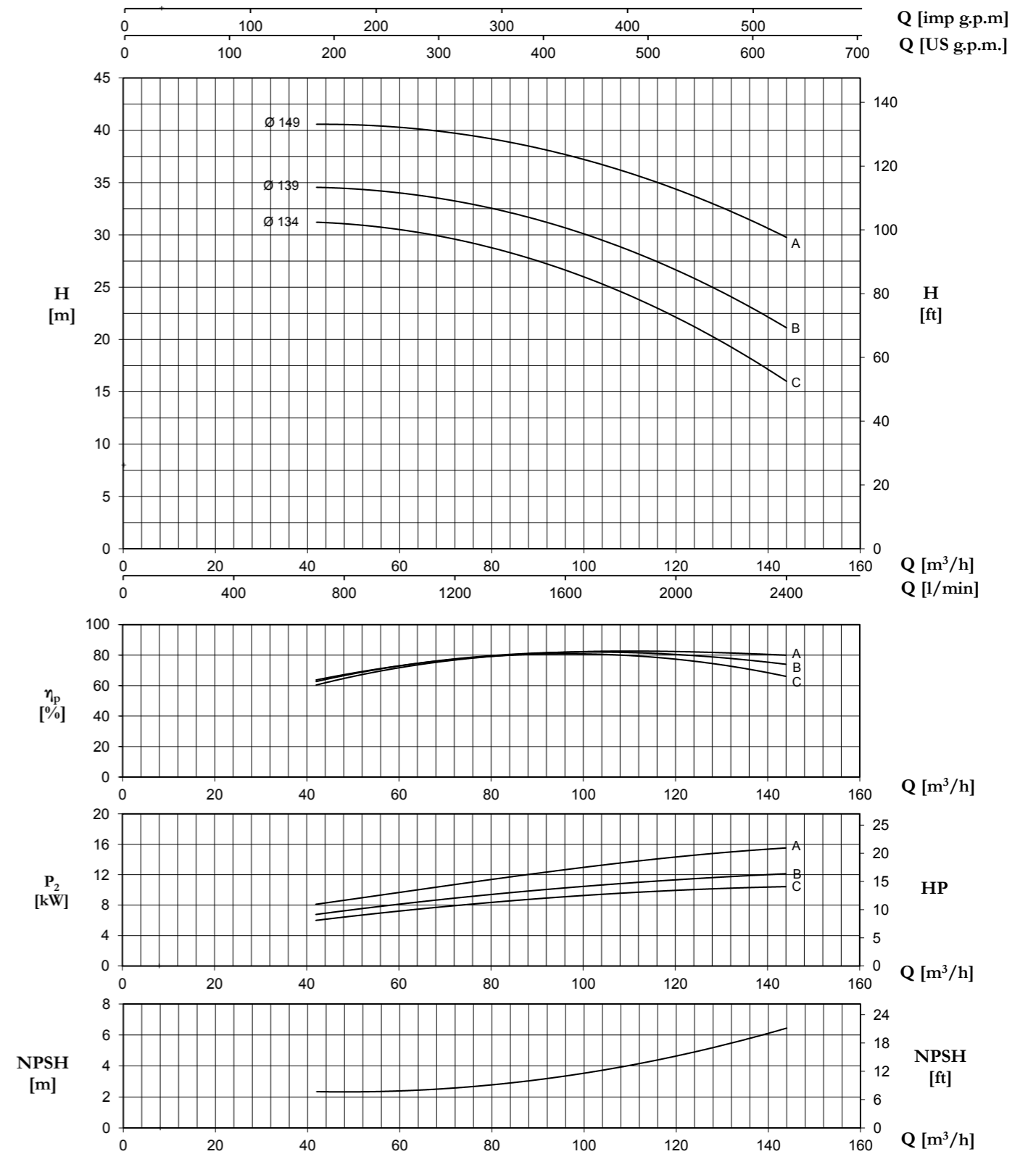

Tolerance: ISO 9906:2012 - Grade 3B

TYPE	Nominal Power (kW)	Motor Size	Q (m³/h - l/min)											
			H (m) / pump input power (kW)											
			0	42	48	60	72	78	84	108	132	144	144	144
65-160C	11	160M	29,8 3,09	31,2 6,00	31,1 6,42	30,5 7,21	29,6 7,93	29,0 8,25	28,3 8,55	24,6 9,56	19,3 10,23	16,0 10,43		
65-160B	11	160M	33,0 3,49	34,6 6,79	34,4 7,24	34,0 8,09	33,3 8,91	32,8 9,29	32,1 9,63	28,8 10,85	24,1 11,70	21,1 12,16		
65-160A	15	160M	39,2 4,65	40,6 8,10	40,6 8,64	40,2 9,66	39,7 10,68	39,4 11,19	38,9 11,69	36,2 13,55	32,2 14,93	29,8 15,55		

65-200

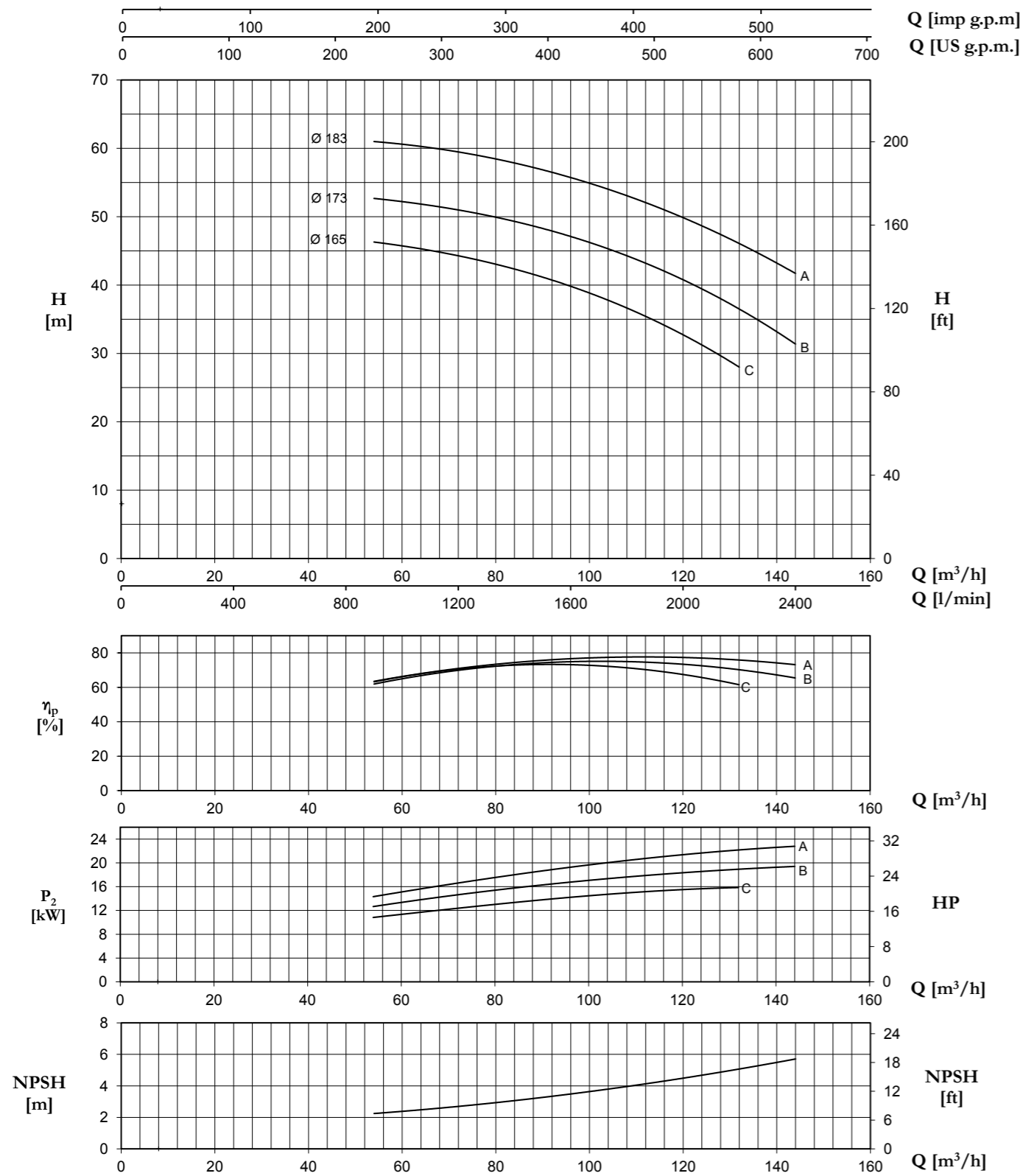

Tolerance: ISO 9906:2012 - Grade 3B

TYPE	Nominal Power (kW)	Motor Size	Q (m ³ /h - l/min)																							
			0	54	60	66	72	78	84	96	108	120	132	144	0	900	1000	1100	1200	1300	1400	1600	1800	2000	2200	2400
			H (m) / pump input power (kW)																							
65-200C	15	160M	45,3	46,3	45,7	45,1	44,3	43,4	42,3	39,8	36,7	32,7	28,0		4,9	10,8	11,3	11,8	12,3	12,9	13,3	13,8	14,9	15,4	15,8	
65-200B	18,5	160L	51,6	52,6	52,2	51,8	51,0	50,2	49,3	47,1	44,1	40,9	36,6	31,3	5,4	11,6	12,2	13,0	13,8	14,3	15,0	16,0	16,7	17,5	18,2	18,6
65-200A	22	180M	60,2	61,0	60,6	60,1	59,5	58,7	57,8	55,8	53,1	49,8	46,1	41,7	7,6	14,9	15,4	16,2	17,1	17,9	18,8	19,8	20,9	22,0	22,8	23,3

65-250

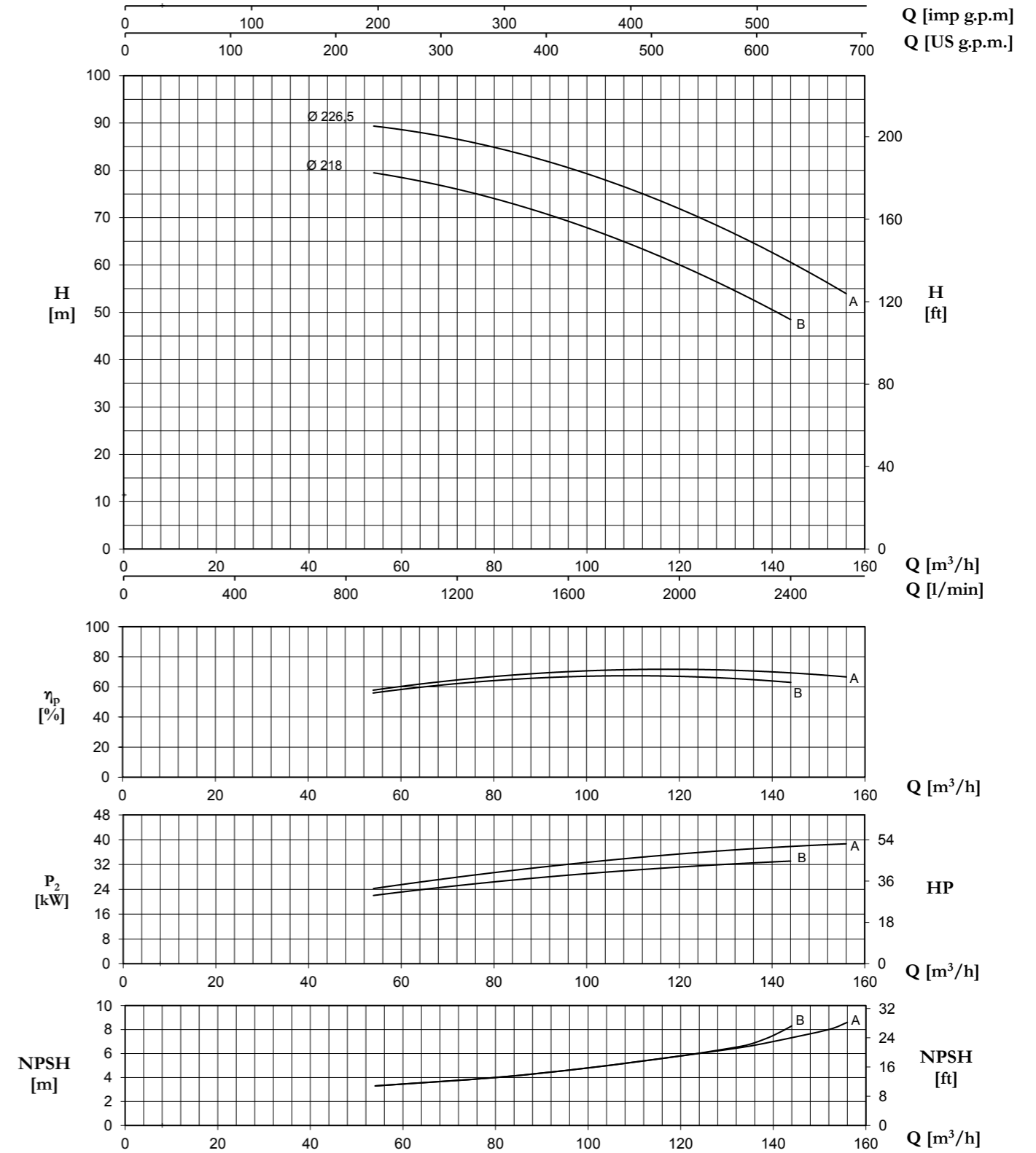

Tolerance: ISO 9906:2012 - Grade 3B

TYPE	Nominal Power (kW)	Motor Size	Q (m ³ /h - l/min)																									
			0	54	60	66	72	78	84	96	108	120	132	144	156	0	900	1000	1100	1200	1300	1400	1600	1800	2000	2200	2400	2600
			H (m) / pump input power (kW)																									
65-250B	30	200L	81,0	79,5	78,5	77,3	76,0	74,5	73,0	69,3	65,0	60,0	54,5	48,5	10,71	22,03	23,12	24,17	25,16	26,08	26,94	28,60	30,01	31,18	32,16	33,14		
65-250A	37	200L	90,0	89,5	88,5	87,5	86,5	85,5	84,0	80,5	76,5	72,0	66,5	60,5	12,09	24,25	25,52	26,73	27,90	29,05	30,15	32,07	33,78	35,41	36,76	37,84	38,67	

65-315

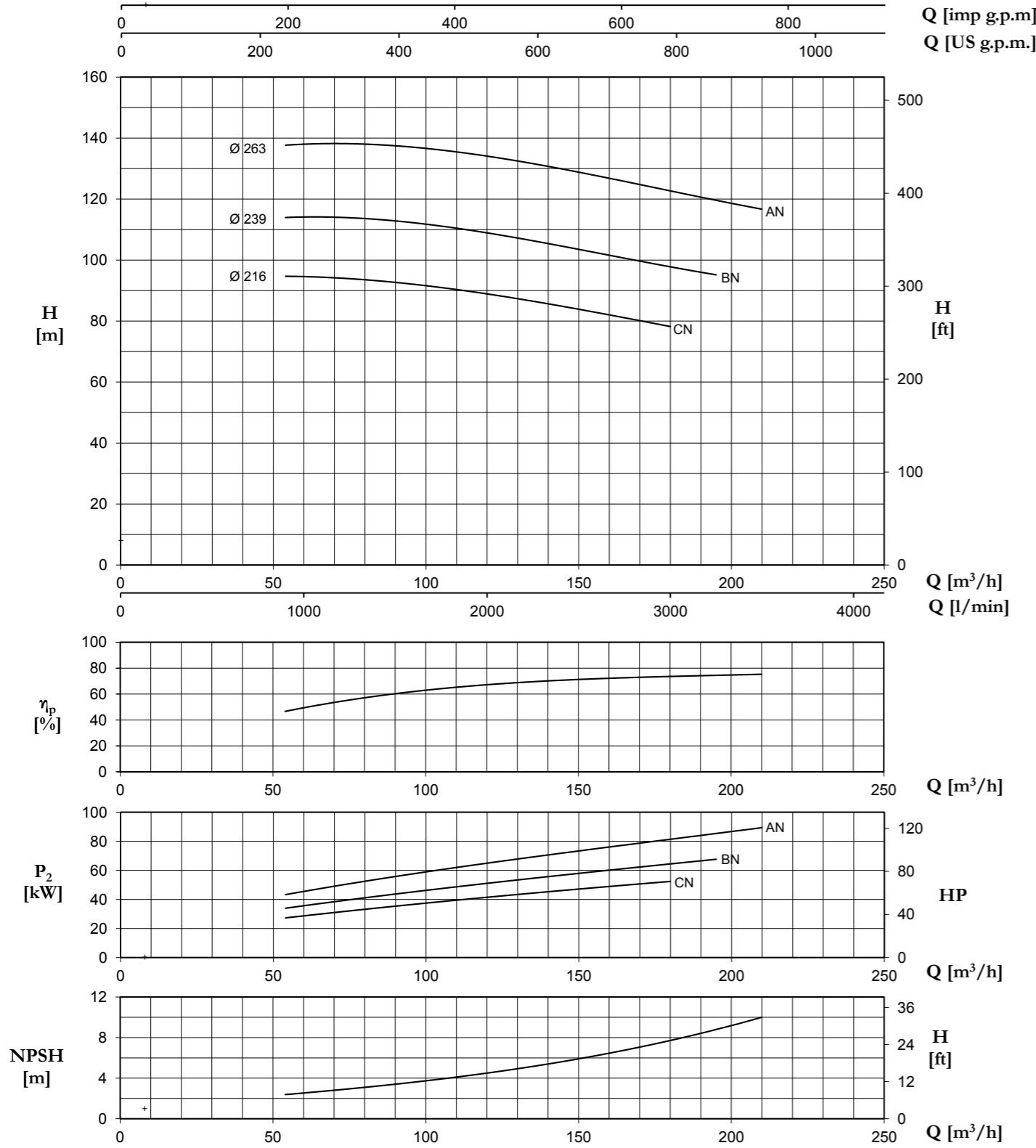

Tolerance: ISO 9906:2012 - Grade 3B

TYPE	Nominal Power (kW)	Motor Size	Q (m³/h - l/min)											
			0	54	66	78	96	120	144	180	195	210		
			0	900	1100	1300	1600	2000	2400	3000	3250	3500		
H (m) / pump input power (kW)														
65-315CN	55	250M	89,1	94,6	94,6	93,7	92,1	88,6	85,2	78,2				
			14,88	27,27	30,09	32,74	36,56	41,55	45,95	52,38				
65-315BN	75	280S	109,3	113,8	114,2	113,9	112,4	108,6	104,4	98,5	94,8			
			19,73	33,93	37,33	40,50	45,26	51,13	56,45	64,51	67,56			
65-315AN	90	280M	132,5	137,4	138,3	138,3	137,3	133,8	129,5	123,0	120,1	116,3		
			26,42	43,32	47,69	51,74	57,58	64,98	71,78	81,56	84,90	89,60		

80-160

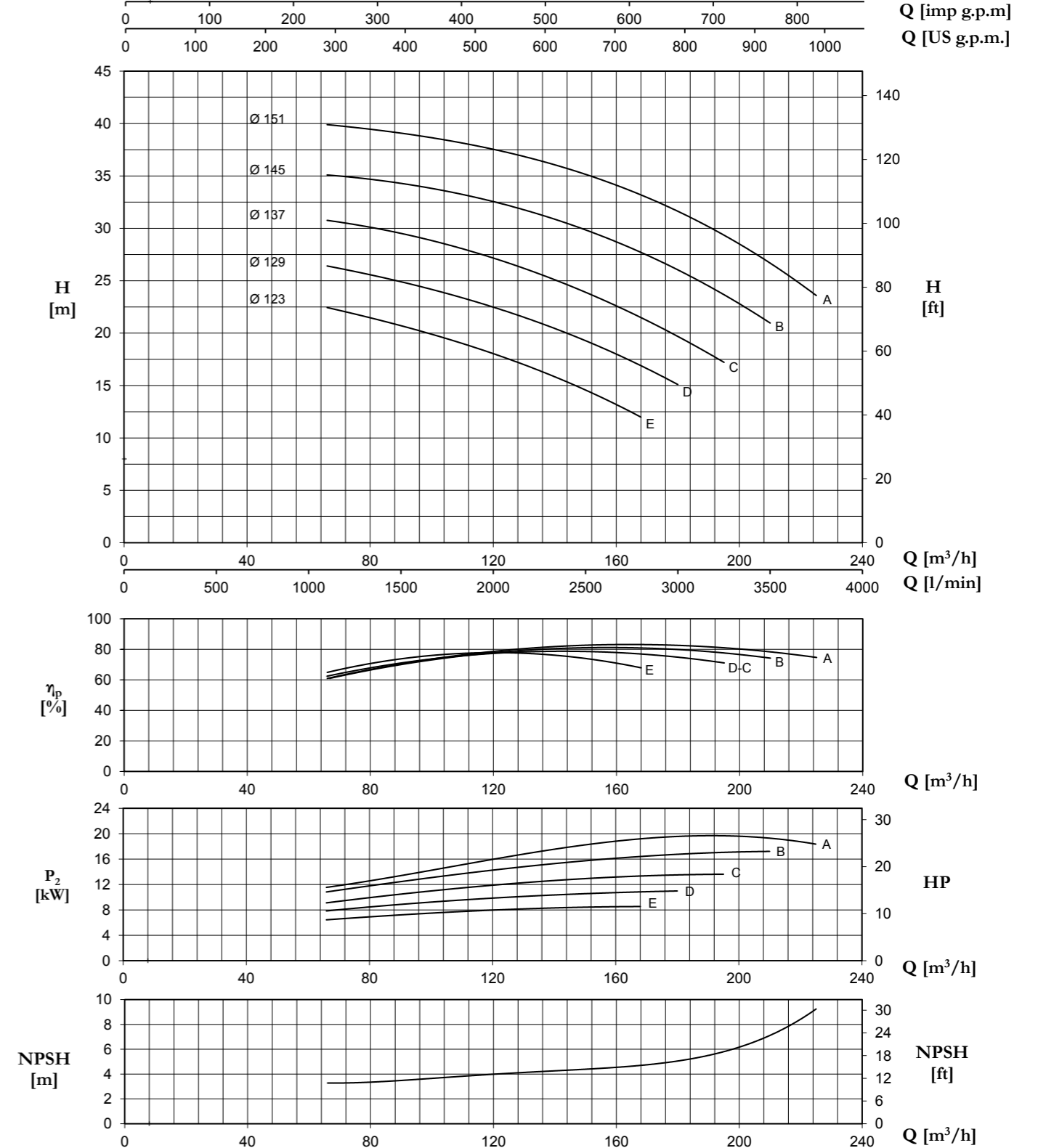

Tolerance: ISO 9906:2012 - Grade 3B

TYPE	Nominal Power (kW)	Motor Size	Q (m³/h - l/min)															
			0	66	72	78	84	96	108	120	132	144	156	168	180	195	210	225
			0	1100	1200	1300	1400	1600	1800	2000	2200	2400	2600	2800	3000	3250	3500	3750
H (m) / pump input power (kW)																		
80-160E	11	160M	21,4	22,4	22,1	21,6	21,2	20,2	19,2	18,0	16,8	15,4	13,7	12,0				
			3,6	6,3	6,6	6,8	7,0	7,3	7,6	8,0	8,2	8,4	8,5	8,4				
80-160D	11	160M	25,4	26,4	26,1	25,7	25,3	24,4	23,6	22,5	21,3	20,0	18,5	16,9	15,1			
			4,0	8,0	8,2	8,5	8,8	9,1	9,5	9,9	10,2	10,5	10,7	10,9	10,9			
80-160C	15	160M	29,7	30,7	30,5	30,3	29,9	29,2	28,1	27,1	26,0	24,7	23,1	21,5	19,7	17,2		
			5,2	9,0	9,3	9,7	10,2	10,7	11,1	11,7	12,3	12,7	13,0	13,3	13,5	13,5	13,5	
80-160B	18,5	160L	34,0	35,0	35,0	34,8	34,6	34,0	33,3	32,5	31,6	30,5	29,2	27,8	26,0	23,6	21,0	
			5,7	9,1	10,2	10,8	11,2	11,6	12,6	13,3	13,9	14,6	15,1	15,4	15,8	16,0	16,3	
80-160A	22	180M	38,8	39,8	39,7	39,6	39,4	38,9	38,2	37,5	36,7	35,7	34,5	33,2	31,6	29,4	26,8	23,5
			7,3	12,0	12,7	13,3	13,7	14,6	15,6	16,5	17,3	18,0	18,7	19,3	19,8	20,3	21,0	20,1

80-200

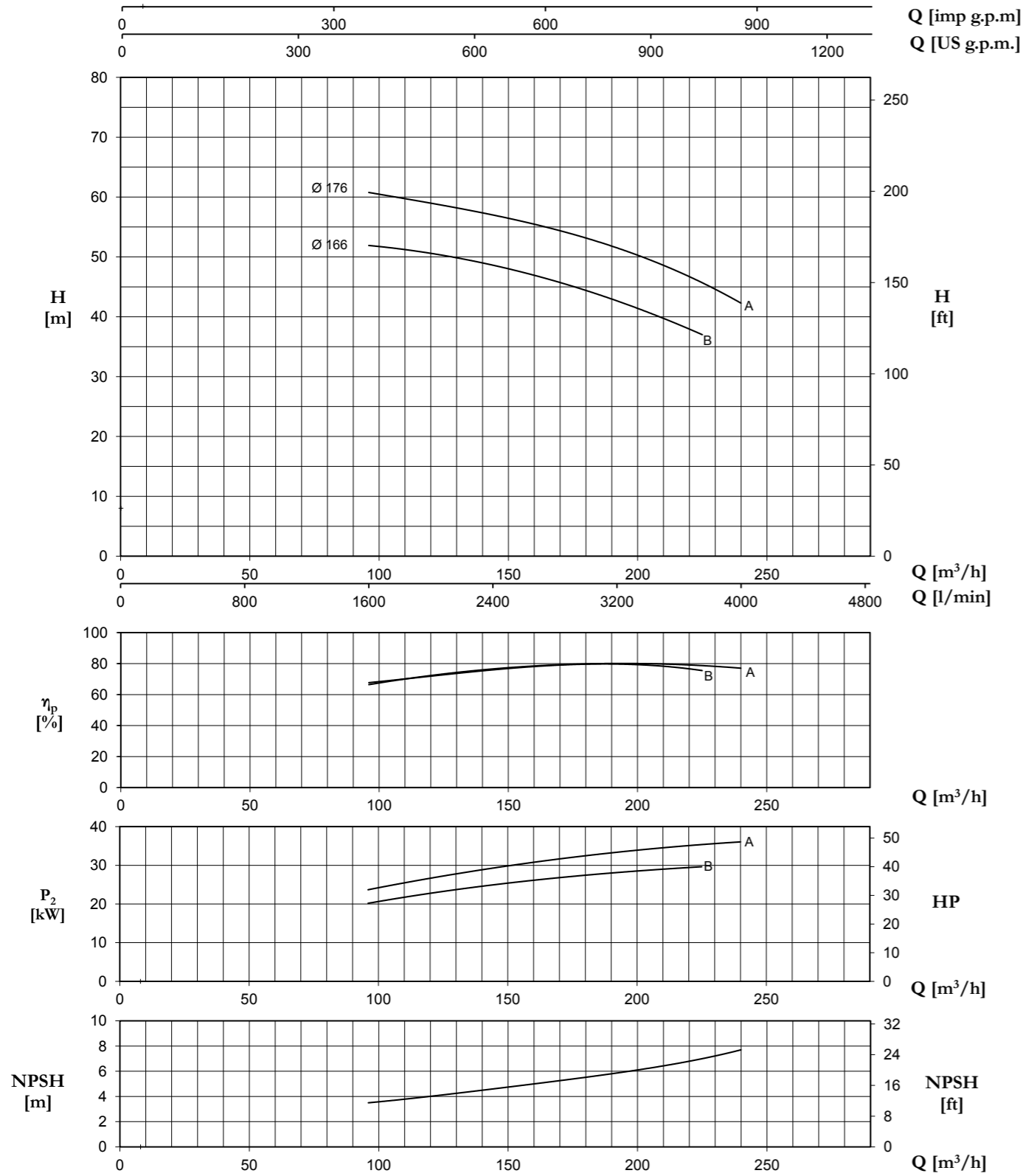

TYPE	Nominal Power (kW)	Motor Size	Q (m³/h - l/min)																			
			0	96	120	132	156	168	180	210	225	240	0	1600	2000	2200	2600	2800	3000	3500	3750	4000
			H (m) / pump input power (kW)																			
80-200B	30	200L	48,5	52,3	50,4	49,4	47,2	46,2	44,9	39,7	36,6		9,74	20,21	22,73	23,94	25,87	26,65	27,38	29,04	29,61	
			56,0	60,8	59,0	58,1	55,8	54,6	53,2	48,6	45,7	42,3		11,33	23,69	26,62	27,96	30,52	31,45	32,37	34,58	35,43
80-200A	37	200L																				

80-250

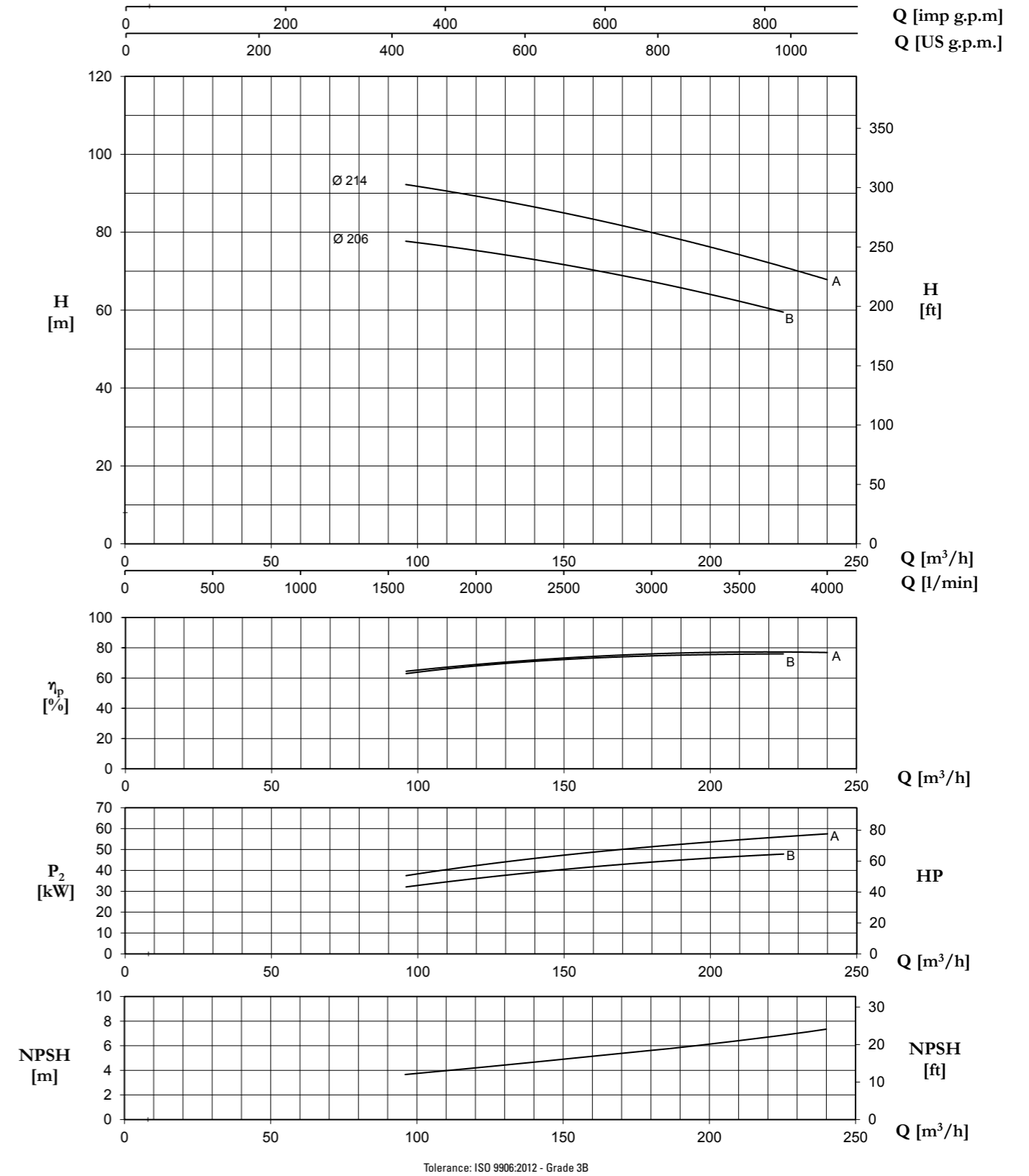

TYPE	Nominal Power (kW)	Motor Size	Q (m³/h - l/min)																			
			0	96	120	132	144	168	180	195	225	240	0	1600	2000	2200	2400	2800	3000	3250	3750	4000
			H (m) / pump input power (kW)																			
80-250 B	45	225M	77,2	77,7	75,2	74,0	72,6	69,1	67,3	64,9	59,5		14,22	32,00	36,41	37,94	39,45	42,67	44,03	45,51	47,80	
			90,0	92,0	89,4	87,9	86,1	81,9	79,7	77,1	71,0	68,0		17,04	37,50	42,26	44,45	46,46	49,83	51,32	53,03	56,20
80-250 A	55	250M																				

100-200

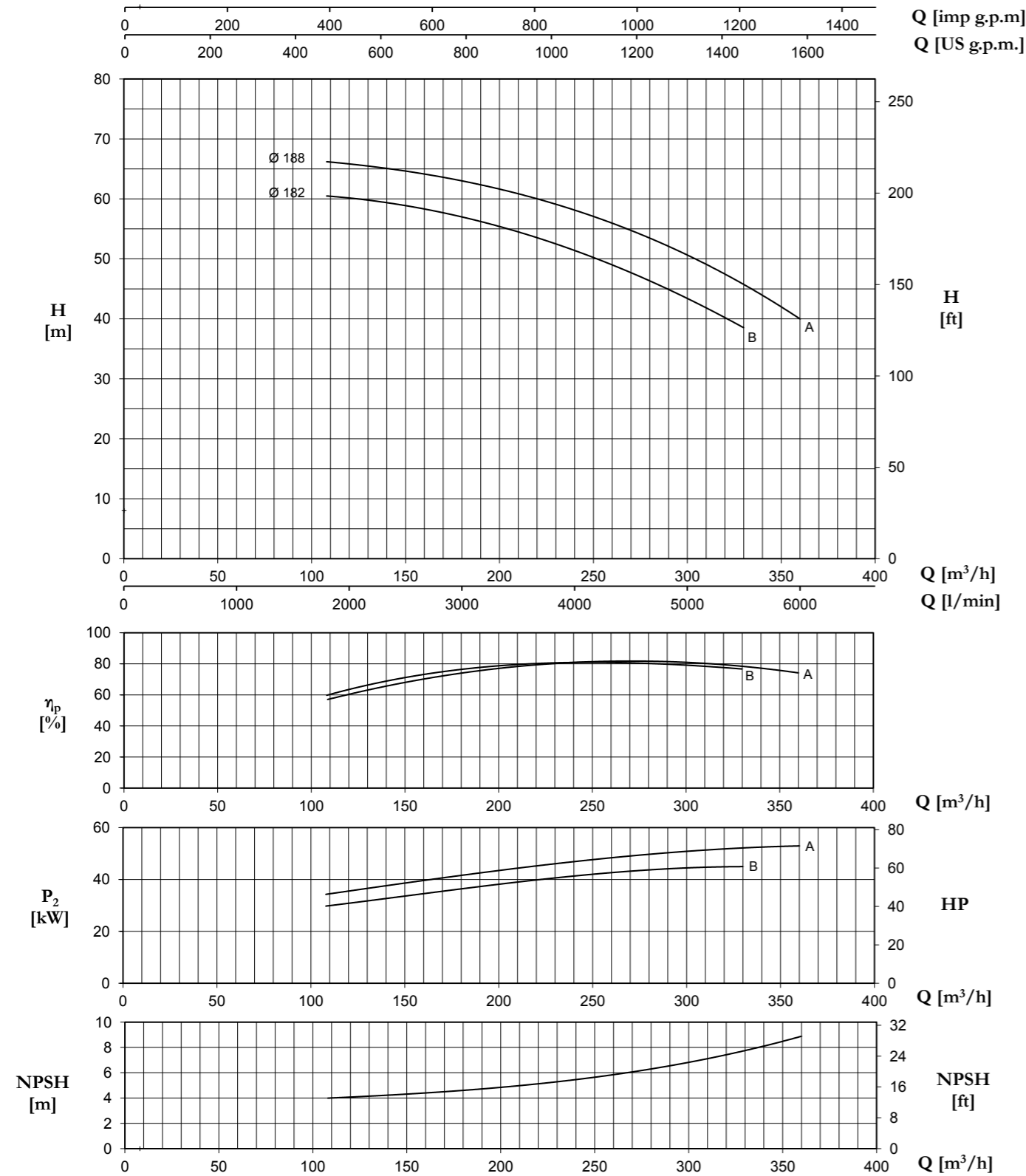

Tolerance: ISO 9906:2012 - Grade 3B

TYPE	Nominal Power (kW)	Motor Size	Q (m³/h - l/min)														
			H (m) / pump input power (kW)														
			0	108	120	132	144	156	168	180	195	210	225	240	270	300	330
100-200 B	45	225M	60,2	60,6	60,2	59,6	59,0	58,5	57,9	57,1	55,9	54,6	53,0	51,3	47,7	43,4	38,5
100-200 A	55	250M	65,5	66,3	65,9	65,3	64,7	64,2	63,7	63,1	62,1	61,0	59,7	58,1	54,5	50,4	46,1

100-250

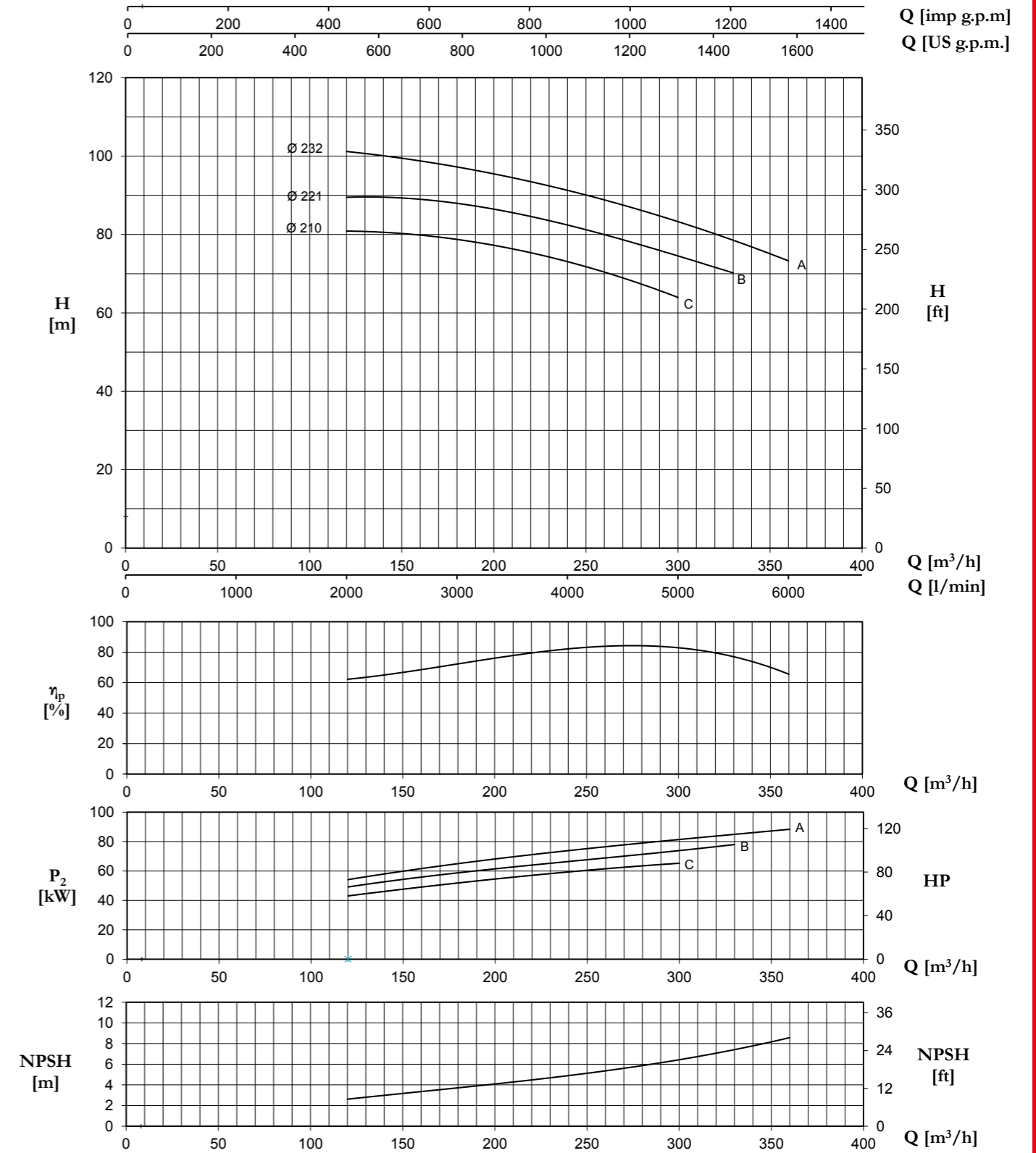

Tolerance: ISO 9906:2012 - Grade 3B

TYPE	Nominal Power (kW)	Motor Size	Q (m³/h - l/min)													
			H (m) / pump input power (kW)													
			0	120	144	168	195	225	270	300	330	360				
100-250 C	55	250M	79,9	81,0	80,4	79,4	77,7	74,9	68,6	64,1						
100-250 B	75	280S	90,0	89,9	89,2	88,2	86,8	84,7	78,4	73,2	70,9					
100-250 A	90	280M	100,5	100,7	99,8	98,4	96,4	93,2	87,1	81,8	78,7	74,0				

CA/CAT - CAX EN 733 ~ 3450 r.p.m.
4CA/4CAT - 4CAX EN 733 ~ 1750 r.p.m.

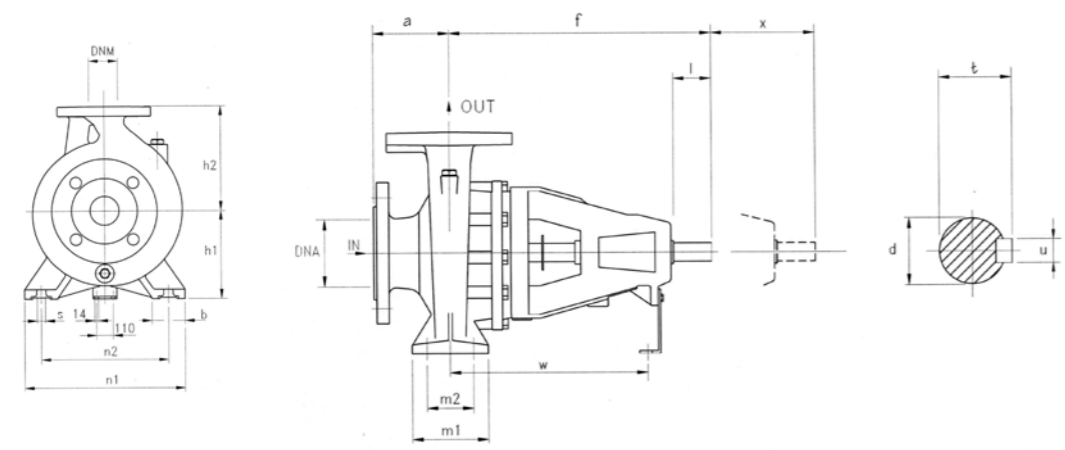

TYPE	DIMENSIONS (mm)																			I	L	M	Kg
	DNA	DNM	a	f	h1	h2	m1	m2	n1	n2	s	b	l	d	t	u	x	w					
32-160	50	32	80	360	132	160	100	70	240	190	14	50	50	24	27	8	100	260	535	320	445	37,5	
32-200			80	360	160	180	100	70	240	190	14	50	50	24	27	8	100	260	535	320	445	40	
32-250			100	360	180	225	125	95	320	250	14	65	65	24	27	8	100	260	680	405	545	48,5	
40-125	65	40	80	360	112	140	100	70	210	160	14	50	50	24	27	8	100	260	535	320	445	36,5	
40-160			80	360	132	160	100	70	240	190	14	50	50	24	27	8	100	260	535	320	445	38,5	
40-200			100	360	160	180	100	70	265	212	14	50	50	24	27	8	100	260	535	320	445	42,5	
40-250			100	360	180	225	125	95	320	250	14	65	50	24	27	8	100	260	680	405	545	47,5	
50-125	65	50	100	360	132	160	100	70	240	190	14	50	50	24	27	8	100	260	535	320	445	39	
50-160			100	360	160	180	100	70	265	212	14	50	50	24	27	8	100	260	535	320	445	43	
50-200			100	360	160	200	100	70	265	212	14	50	50	24	27	8	100	260	535	320	445	46	
50-250			100	360	180	225	125	95	320	250	14	65	50	24	27	8	100	260	680	405	545	52,5	
50-315			80	125	470	225	280	125	95	345	280	14	65	80	32	35,3	10	100	340	655	465	620	93
65-125	80	65	100	360	160	180	125	95	280	212	14	65	65	24	27	8	100	260	535	320	445	44,5	
65-160			100	360	160	200	125	95	280	212	14	65	65	24	27	8	100	260	535	320	445	48,5	
65-200			100	360	180	225	125	95	320	250	14	65	65	24	27	8	140	260	680	405	545	53	
65-250			100	470	200	250	160	120	360	280	19	80	80	32	35	10	140	340	680	405	545	76	
65-315			125	470	225	280	160	120	400	315	19	80	80	32	35	10	140	340	655	465	620	99,5	
80-160	100	80	125	360	180	225	125	95	320	250	14	65	50	24	27	8	140	260	680	405	545	57,5	
80-200			125	470	180	250	125	95	345	280	14	65	80	32	35	10	140	340	680	405	545	73	
80-250			125	470	200	280	160	120	400	315	18	80	80	32	35,3	10	140	340	655	465	585	89,5	
80-315			125	470	250	315	160	120	400	315	18	80	80	32	35,3	10	140	340	655	465	620	106	
100-200	125	100	125	470	200	280	160	120	360	286	18	80	80	32	35,3	10	140	340	655	465	620	95	
100-250			140	470	225	280	160	120	400	315	18	80	80	32	35,3	10	140	340	655	465	620	103	
100-315			140	470	250	315	160	120	400	315	18	80	80	32	35,3	10	140	340	655	465	620	122	
100-400			140	530	280	355	200	150	500	400	22	100	110	42	45,3	12	140	370	720	775	855	183,5	
125-250	150	125	160	530	315	450	200	150	400	315	22	100	110	32	45,3	12	140	370	655	465	620	132	
125-315			140	530	280	355	200	150	500	400	22	100	110	42	45,3	12	140	370	720	775	855	169	
125-400			140	530	315	400	200	150	500	400	22	100	110	42	45,3	12	140	370	720	775	855	190,5	
150-315	200	150	160	530	280	400	200	150	550	450	22	100	110	42	45,3	12	140	370	655	465	620	186,5	
150-400	200	150	160	530	315	450	200	150	550	450	22	100	110	42	45,3	12	140	370	720	775	855	214	
200-315	250	200	180	706	355	450	250	190	634	500	28	134	110	55	58,3	16	208	523	800	1200	1150	345	
200-400			180	706	355	500	250	190	634	500	28	134	110	55	58,3	16	214	523	800	1200	1150	346	
250-315	300	250	225	711	400	500	250	200	694	560	28	134	110	55	58,3	16	214	528	800	1200			
250-400			225	706	400	550	250	200	694	560	28	134	110	55	58,3	16	220	523	800	1200			

flanges

DN	D	K	holes	
			n°	Ø
32	140	100	4	18
40	150	110	4	18
50	165	125	4	18
65	185	145	4	18
80	200	160	8	18
100	220	180	8	18
125	250	210	8	18
150	285	240	8	23
200	340	295	8	23
250	395	350	12	23
300	445	400	12	23

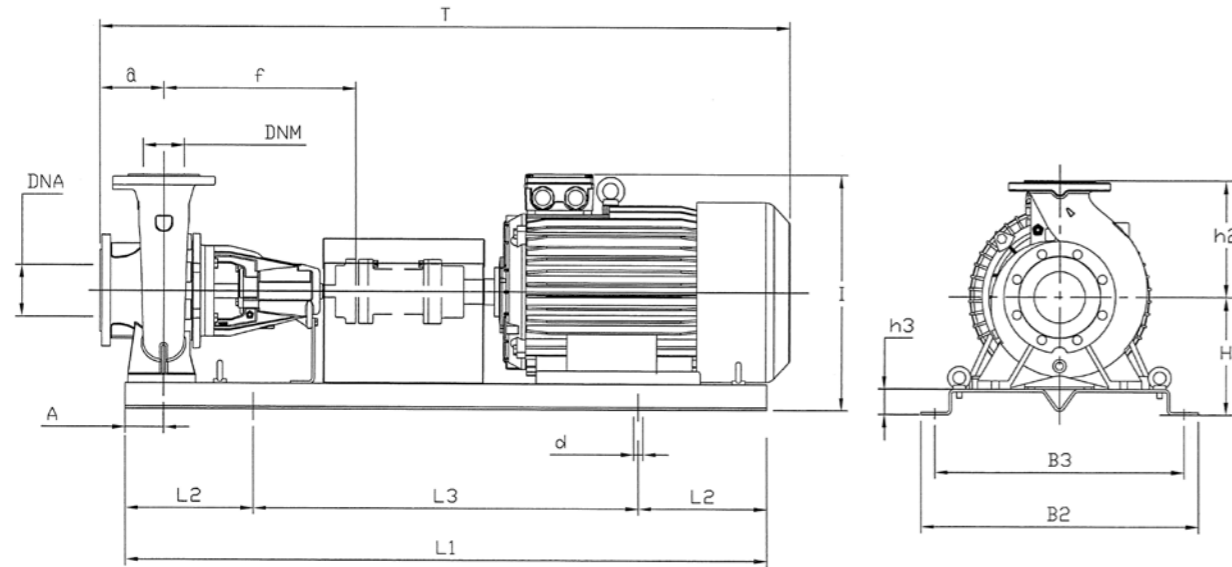

TYPE	kW	Motor Size	DIMENSIONS (mm)																Kg
			DNA	DNM	a	f	H	h2	h3	L1	L2	L3	B2	B3	A	d	T	I	
32-160C	1,5	90S	50	32	80	360	182	160	50	800	130	540	360	320	60	18	855	342	82
32-160C	2,2	90L	50	32	80	360	182	160	50	900	150	600	390	350	60	18	920	342	88
32-160B	2,2	90L	50	32	80	360	182	160	50	900	150	600	390	350	60	18	920	342	87,7
32-160A	3	100L	50	32	80	360	182	160	50	900	150	600	390	350	60	18	920	362	95,7
32-160A	4	112M	50	32	80	360	182	160	50	900	150	600	390	350	60	18	940	375	102,7
32-200C	4	112M	50	32	80	360	210	180	50	900	150	600	390	350	60	18	940	403	106,7
32-200B	5,5	132S	50	32	80	360	210	180	50	1000	170	660	450	400	60	22	1020	433	131,3
32-200A	7,5	132S	50	32	80	360	210	180	50	1000	170	660	450	400	60	22	1020	433	134,3
32-250C	11	160M	50	32	100	360	230	225	50	1250	205	840	540	490	75	22	1275	495	196,3
32-250B	11	160M	50	32	100	360	230	225	50	1250	205	840	540	490	75	22	1275	495	196,3
32-250B	15	160M	50	32	100	360	230	225	50	1250	205	840	540	490	75	22	1275	495	206,3
32-250A	15	160M	50	32	100	360	230	225	50	1250	205	840	540	490	75	22	1275	495	206,3
40-125C	1,5	90S	65	40	80	360	162	140	50	800	130	540	360	320	60	18	855	317	82,2
40-125B	2,2	90L	65	40	80	360	162	140	50	900	150	600	390	350	60	18	920	317	87,8
40-125A	3	100L	65	40	80	360	162	140	50	900	150	600	390	350	60	18	920	342	95,8
40-160B	3	100L	65	40	80	360	182	160	50	900	150	600	390	350	60	18	920	362	98,8
40-160B	4	112M	65	40	80	360	182	160	50	900	150	600	390	350	60	18	940	375	105,8
40-160A	4	112M	65	40	80	360	182	160	50	900	150	600	390	350	60	18	940	375	105,8
40-160A	5,5	132S	65	40	80	360	182	160	50	1000	170	660	450	400	60	22	1020	405	130,4
40-200B	5,5	132S	65	40	100	360	210	180	50	1000	170	660	450	400	60	22	1040	433	134,4
40-200A	7,5	132S	65	40	100	360	210	180	50	1000	170	660	450	400	60	22	1040	433	137,4
40-250C	11	160M	65	40	100	360	230	225	50	1250	205	840	540	490	75	22	1275	495	197,9
40-250B	11	160M	65	40	100	360	230	225	50	1250	205	840	540	490	75	22	1275	495	197,9
40-250B	15	160M	65	40	100	360	230	225	50	1250	205	840	540	490	75	22	1275	495	207,9
40-250A	15	160M	65	40	100	360	230	225	50	1250	205	840	540	490	75	22	1275	495	207,9
40-250A	18,5	160L	65	40	100	360	230	225	50	1250	205	840	540	490	75	22	1275	495	224,9
40-250BM	18,5	160L	65	40	100	360	230	225	50	1250	205	840	540	490	75	22	1275	495	224,9
40-250AM	22	180M	65	40	100	360	230	225	50	1250	205	840	540	490	75	22	1275	510	264,3

TYPE	kW	Motor Size	DIMENSIONS (mm)																Kg
			DNA	DNM	a	f	H	h2	h3	L1	L2	L3	B2	B3	A	d	T	I	
50-125B	3	100L	65	50	100	360	182	160	50	900	150	600	390	350	60	18	940	362	98,7
50-125B	4	112M	65	50	100	360	182	160	50	900	150	600	390	350	60	18	960	375	105,7
50-125A	4	112M	65	50	100	360	182	160	50	900	150	600	390	350	60	18	960	375	105,7
50-125A	5,5	132S	65	50	100	360	182	160	50	1000	170	660	450	400	60	22	1040	405	130,3
50-160B	5,5	132S	65	50	100	360	210	180	50	1000	170	660	450	400	60	22	1040	433	134,8
50-160A	7,5	132S	65	50	100	360	210	180	50	1000	170	660	450	400	60	22	1040	433	137,8
50-200C	11	160M	65	50	100	360	210	200	50	1120	190	740	490	440	60	22	1168	475	190,8
50-200B	11	160M	65	50	100	360	210	200	50	1120	190	740	490	440	60	22	1168	475	190,8
50-200A	15	160M	65	50	100	360	210	200	50	1120	190	740	490	440	60	22	1168	475	200,8
50-250C	15	160M	65	50	100	360	230	225	50	1250	205	840	540	490	75	22	1275	495	211,8
50-250C	18,5	160L	65	50	100	360	230	225	50	1250	205	840	540	490	75	22	1275	495	228,8
50-250B	18,5	160L	65	50	100	360	230	225	50	1250	205	840	540	490	75	22	1275	495	228,8
50-250B	22	180M	65	50	100	360	230	225	50	1250	205	840	540	490	75	22	1275	510	268,2
50-250A	22	180M	65	50	100	360	230	225	50	1250	205	840	540	490	75	22	1275	510	268,2
50-250A	30	200L	65	50	100	360	230	225	50	1400	230	940	610	550	75	26	1425	560	326,2
50-315DN	37	200L	80	50	125	470	275	280	50	1400	230	940	610	550	75	26	1455	585	387
50-315CN	45	225M	80	50	125	470	275	280	50	1400	230	940	610	550	75	26	1500	605	452,8
50-315BN	55	250M	80	50	125	470	310	280	85	1600	270	1060	660	600	75	26	1650	710	573,8
50-315AN	75	280S	80	50	125	470	310	280	85	1800	300	1200	730	670	75	26	1850	770	726,8
65-125B	5,5	132S	80	65	100	360	210	180	50	1000	170	660	450	400	60	22	1040	433	136,6
65-125A	7,5	132S	80	65	100	360	210	180	50	1000	170	660	450	400	60	22	1040	433	136,6
65-160C	11	160M	80	65	100	360	210	200	50	1120	190	740	490	440	60	22	1168	475	194,1
65-160B	11	160M	80	65	100	360	210	200	50	1120	190	740	490	440	60	22	1168	475	194,1
65-160A	15	160M	80	65	100	360	210	200	50	1120	190	740	490	440	60	22	1168	475	204,1
65-200C	15	160M	80	65	100	360	230	225	50	1250	205	840	540	490	75	22	1275	495	214,5
65-200B	18,5	160L	80	65	100	360	230	225	50	1250	205	840	540	490	75	22	1275	495	231,5
65-200A	22	180M	80	65	100	360	230	225	50	1250	205	840	540	490	75	22	1290	510	270,3
65-250B	30	200L	80	65	100	470	250	250	50	1400	230	940	610	550	90	26	1470	560	350,8
65-250A	37	200L	80	65	100	470	250	250	50	1400	230	940	610	550	90	26	1470	560	369,8
65-315CN	55	250M	80	65	125	470	310	280	85	1600	270	1060	660	600	90	26	1645	710	576,2
65-315BN	75	280S	80	65	125	470	310	280	85	1800	300	1200	730	670	90	26	1835	770	729,2
65-315AN	90	280M	80	65	125	470	310	280	85	1800	300	1200	730	670	90	26	1835	770	759,2
80-160E	11	160M	100	80	125	360	230	225	50	1250	205	840	540	490	75	22	1300	495	209,8
80-160D	11	160M	100	80	125	360	230	225	50	1250	205	840	540	490	75	22	1300	495	209,8
80-160C	15	160M	100	80	125	360	230	225	50	1250	205	840	540	490	75	22	1300	495	219,8
80-160B	18,5	160L	100	80	125	360	230	225	50	1250	205	840	540	490	75	22	1300	495	236,8
80-160A	22	180M	100	80	125	360	230	225	50	1250	205	840	540	490	75	22	1315	510	275,7
80-200B	30	200L	100	80	125	470	230	250	50	1400	230	940	610	550	75	26	1495	560	349,7
80-200A	37	200L	100	80	125	470	230	250	50	1400	230	940	610	550	75	26	1495	560	368,7
80-250B	45	225M	100	80	125	470	250	280	50	1400	230	940	610	550	90	26	1540	605	451,5
80-250A	55	250M	100	80	125	470	285	280	85	1600	270	1060	660	600	90	26	1645	710	572,5
100-200B	45	225M	125	100	125	470	250	280											