



Pompe da drenaggio con girante "Bicanale" per il pompaggio di acque cariche e liquidi con corpi in sospensione; ideali nelle applicazioni civili e domestiche.

Drainage pump with "Double-Channel" impeller for pumping charged waters and liquids with suspended solids; ideal for civil and household applications.

Bombas de drenaje con turbina "Bicanal" para bombear aguas cargadas y líquidos con cuerpos en suspensión; ideales en las aplicaciones civiles y domésticas.

Pompes de drainage avec turbine "Bicanal" pour le pompage d'eaux chargées et de liquides avec corps en suspension; idéales dans les applications civiles et domestiques.

**CARATTERISTICHE COSTRUTTIVE / CONSTRUCTION FEATURES
CARACTERÍSTICAS CONSTRUCTIVAS / CARACTÉRISTIQUES D'EXÉCUTION**

Corpo pompa	ghisa
Pump body	cast iron
Cuerpo bomba	fundición
Corps de pompe	fonte
Camicia, coperchio motore, base appoggio	acciaio inox
Shell, motor cover, base support	stainless steel
Camisa, tapa motor, base apoyo	acero inoxidable
Chemise, couvercle moteur, support de base	acier inox
Girante	acciaio inox
Impeller	stainless steel
Rodete	acero inoxidable
Turbine	acier inox
Tenuta meccanica	doppia tenuta con barriera d'olio: carburo di silicio lato pompa, ceramica-grafite lato motore
Mechanical seal	double seal with oil barrier; silicon carbide on pump side, ceramic-graphite on motor side
Sello mecánico	doble sello con cámara interpuesta: carburo de silicio lado bomba, cerámica-grafito lado motor
Garniture mécanique	double garniture avec film lubrifiant: carbure de silice côté pompe, céramique-graphite côté moteur
Albero motore	acciaio AISI 430
Motor shaft	stainless steel AISI 430
Eje motor	acero AISI 430
Arbre moteur	acier AISI 430
Passaggio corpi solidi	
Passage of solids	Ø max 50 mm
Pajo de solidos	
Passage corps solides	
Profondità di immersione	
Depth of immersion	max 5 m
Profundidad inmersión	
Profondeur immersion	
Temperatura del liquido	
Liquid temperature	0 - 40 °C
Temperatura del liquido	
Température du liquide	
Cavo	
Cable	H07 RNF, 10 m
Cable	
Câble	
	galleggiante
	float switch
G	flotador
	flotteur
MOTORE / MOTOR / MOTOR / MOTEUR	
Motore 2 poli a induzione	3~ 230/400V-50Hz
2 pole induction motor	1~ 230V-50Hz
Motor de 2 polos a inducción	con termoprotettore
Moteur à induction à 2 pôles	with thermal protection
	con protección térmica
	avec protection thermique
Classe di isolamento	
Insulation class	F
Clase de aislamiento	
Classe d'isolation	
Grado di protezione	
Protection degree	IP68
Grado de protección	
Protection	



TYPE	TRUCK		CONTAINER	
	PALLET (cm)	N° pumps	PALLET (cm)	N° pumps
DB	80X120X145	57	80X120X190	76

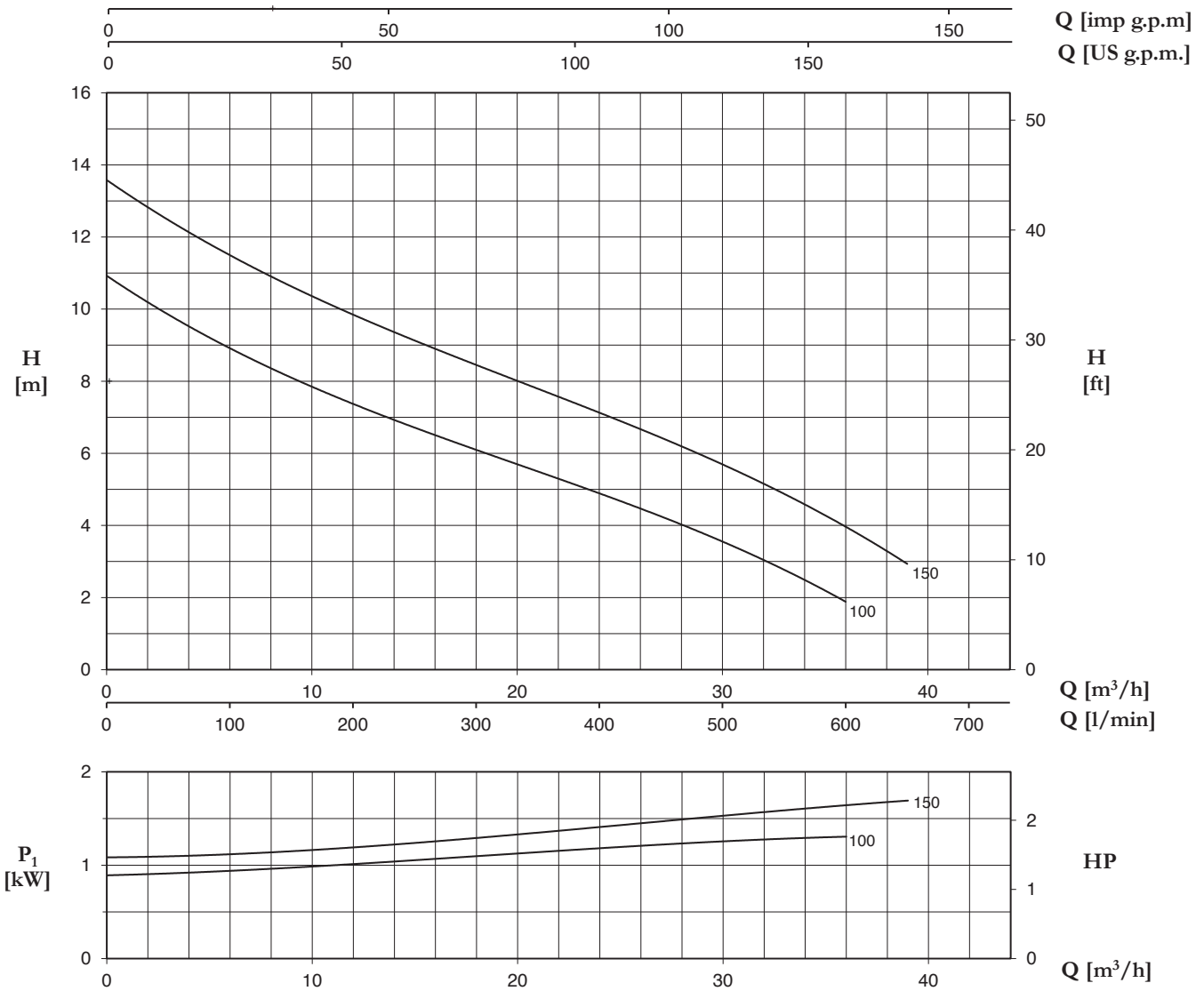

TYPE		W	AMPERE		Q (m³/h - l/min)							
1~	3~		1~	3~	0	6	12	18	24	30	36	39
			1x230 V 50 Hz	3x400 V 50 Hz	0	100	200	300	400	500	600	650
DB 100 (G)	DBT 100	1350	5,9	2,8	11,0	8,7	7,5	6,3	4,9	3,4	2,0	-
DB 150 (G)	DBT 150	1700	8,0	3,0	13,6	11,4	9,8	8,6	7,2	5,6	3,9	3,0

E: massimo livello di svuotamento
 E: maximum emptying level
 E: máximo nivel de vaciado
 E: niveau maximum de vidange

Mt: livello minimo di funzionamento continuo
 Mt: lowest level for continuous duty
 Mt: nivel mínimo de funcionamiento continuo
 Mt: niveau minimum de fonctionnement continuu

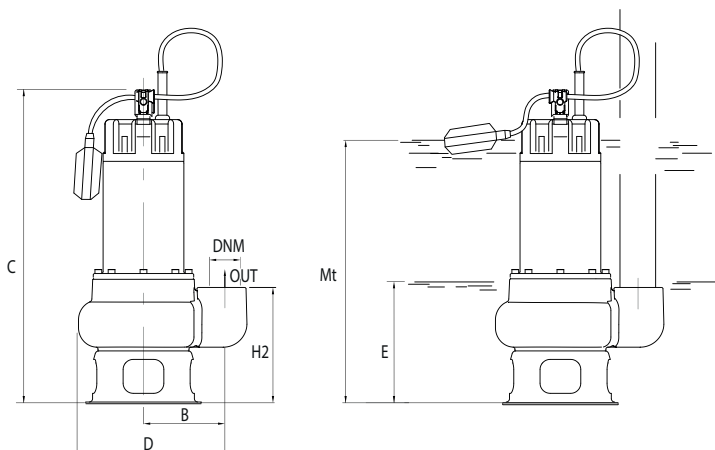

TYPE	DIMENSIONS (mm)										Kg
	B	C	D	E	H2	Mt	DNM	I	L	M	
DB 100 (G)	142,5	461	247,5	185	170	390	2" G	200	260	470	15
DB 150 (G)	142,5	461	247,5	185	170	390	2" G	200	260	470	17